



373 ATASCOCITA RD. • HUMBLE, TX • 77396  
TEL (281) 441-6500 • FAX (281) 441-6510  
<< www.aspenmfg.com >>

# INSTALLATION INSTRUCTION

## AFW SERIES HYDRONIC VERTICAL WALL MOUNT AIR HANDLER

**IMPORTANT MESSAGE TO INSTALLER:** "The United States Environmental Protection Agency ("EPA") has issued various regulations regarding the introduction of disposal of refrigerants in this unit. Failure to follow these regulations may harm the environment and can lead to the imposition of substantial fines. Because these regulations may vary due to the passage of new laws we suggest that any work on this unit be done by a certified technician. Should you have any questions please contact the local office of EPA." Some Aspen coils may include a Schrader valve on the suction manifold. During installation, this Schrader valve must be protected from heat or it may leak. All Aspen coils are shipped with a nitrogen holding charge. DO NOT install the coil if this charge is not present.

**IMPORTANT MESSAGE TO OWNER:** These instructions should be carefully read and kept near product, for future reference. While these instructions are addressed primarily to the installer, useful maintenance information is included. Have your installing dealer acquaint you with the operating characteristics of the product and periodic homeowner maintenance requirements. As expressed in our product warranty, Aspen will not be billed for any structural damage due to failure to follow these installation requirements. Once installed, Aspen coils may contain chlorofluorocarbons (CFC's) or hydrochlorofluorocarbons (HCFC's). Under certain conditions, CFC's & HCFC's may pose a health risk. Please notify a licensed service technician immediately if you suspect your system may contain a leak.

### CODES AND REGULATIONS

This product is designed and manufactured to permit installation in accordance with National Codes. It is the installer's responsibility to install the product in accordance with National Codes and/or prevailing local codes and regulations. The manufacturer assumes no responsibility for equipment installed in violation of any code or regulation.

### INSPECTION

This product has been inspected and run tested at the factory and released to the transportation agency without known damage. Inspect exterior of carton for evidence of rough handling in shipment. Unpack carefully, if damage is found, report immediately to the transportation agency.

### REPLACEMENT PARTS

Order all replacement parts through your local distributor. When ordering parts, give complete model and serial number as shown on the unit rating plate.

### INSTALLATION NOTES

- This unit must be installed in accordance with all local and national codes.
- If screws or holes must be drilled into fan coil cabinet, check carefully to insure that no damage is done to internal components.
- Use a low temperature, NON-LEAD solder on all water line copper joints.
- Insulate all water piping as necessary to prevent freezing.

### WARNING!

If a back flow preventer is installed in the system, an expansion tank is necessary.

### WARNING!

The hot water coil and all water lines must be purged of air before the hot water pump can be energized. Failure to purge the water system of air can result in damage to the pump.

## UNIT INSTALLATION

This unit must be installed in a vertical position with the return at the bottom and the plenum at the top. The return may be ducted through the bottom of the unit by removing the drain access panel and filter, then reattaching the lower access panel. The clearance to combustibles (which includes the cabinet, plenum, and all connecting duct work) is zero inches. However, approximately 20 inches of clearance must be provided at the front of the unit to allow access to internal components. Several installations are possible in this configuration:

- The bracket can be hung on a closet wall by using the factory supplied bracket. To prevent the transfer of normal operational sound through the wall, use a sound deadening or isolating material.
- The unit can be installed on a platform in a closet. Screws or nails must be used to secure the unit in place. The platform must provide ample clearance for drain lines that exit the unit from the bottom.
- The fan coil can be installed in a partition wall as shown in Figure 1. A louvered wall panel or perforated door (made by the coil manufacturer) must be used with this type of installation. The fan coil is installed before the drywall and louvered panel is installed with screws or nails once the drywall is in place.

## AIR DUCT INSTALLATION NOTES

### ELECTRICAL WIRING

All information needed to connect the 120VAC supply and 24VAC control wiring is supplied with the unit (see Figure 2). Two knockouts are located at the top of the unit for connection of power and control wiring. Since this unit is supplied with a 24 volt Class 2 transformer, a thermostat with isolating contacts must be used when connecting other add-on equipment using a Class 2 transformer.

### EVAPORATOR COIL CONNECTIONS

This fan coil uses a factory installed fixed orifice piston to meter the refrigerant for the evaporator coil. This allows the fan coil to be matched with either a heat pump or a standard condensing unit. The size of the suction and liquid refrigerant lines is determined by the instructions supplied with the outdoor unit. The evaporator coil has a nitrogen charge from the factory and must be dumped before being connected. The connections for both the liquid refrigerant and the suction lines are sweated connections.

### HOT WATER CONNECTIONS

The connections to the hot water coil are 3/4" (7/8"OD) copper tubing. The hot water inlet is located on the top right of the unit (a label on the unit clearly identifies the correct connection). All piping connecting the fan coil to the house water system should be 3/4" (7/8"OD) copper tubing or 3/4" nominal CPVC with appropriate CPVC to copper fittings. This size tubing will prevent **DANGER!**

If a ducted return is used, it must have the same free area as the opening on the unit. If a non-ducted return is used, local or national codes may restrict the unit installation to single story residences only.

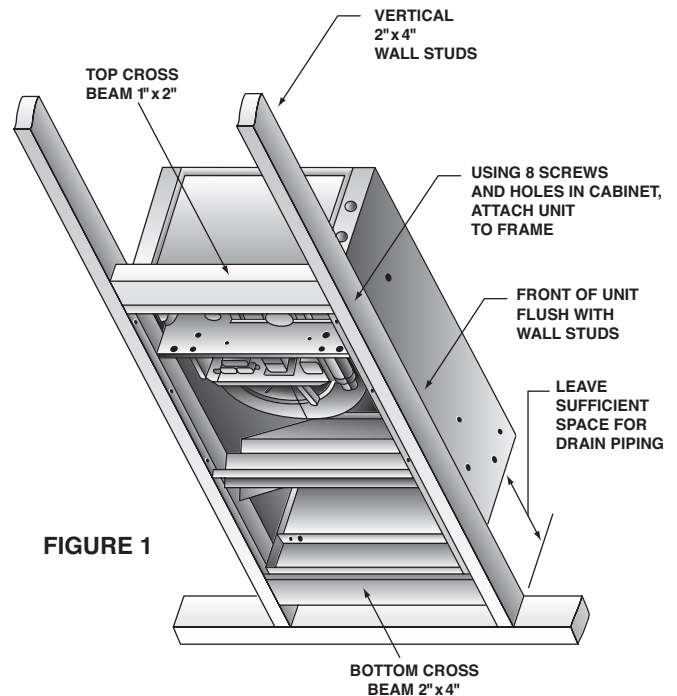

loss of head pressure. The total length of piping used to connect the fan coil to the water heater should not exceed 200 feet for 3/4" nominal copper and 120 feet for 3/4" nominal CPVC. Use "T" fittings at the water heater to connect into the house water system. These "T" fittings must be installed on the vertical hot and cold supply lines of the water heater shown in Figure 3. The connections from the fan coil unit are made to the horizontal connections of the "T" fittings. This will allow air to be purged from the system when water is used in the home. Between the fan coil and water heater connections, two valves (provided by the installer) must be installed to permit purging of air in the system and also to allow the hot water coil in the unit to be separated from the house water system during servicing.

### PURGING THE SYSTEM

1. Open air vent and allow water heater to fill with water. Close air vent when water heater is full and all air has been purged.
2. Ignite water heater. Set thermostat on water heater to 140 degrees.

140-degree water can cause first-degree burns. We strongly recommend the installation of a water-tempering valve ([for water temperatures above 140-degrees](#)) to supply lower temperature water to the fixtures in the house. Use Watts N170L series or equivalent.

1. Close the valve on the hot water supply from the water heater ("A") and open the valve on the cold-water return then the water heater ("B"). Then open the air vent in the fan coil. Use bucket or hose to discard water during purging process at air bleed valve. Purge air completely from lines.
2. Once air is purged, close return valve ("B") and open supply valve ("A"). Purge the coil and lines of air completely.
3. After air is purged from the system and filled with water, open the return valve ("B") and the supply valve ("A"). Then close the air vent in the fan coil.
4. Apply power to the fan coil and set the room thermostat on heat. Raise the temperature setting to activate the circulating pump.
5. Check the pump to insure proper operation. The water inlet of the unit should be hot if the water temperature in the water heater has reached the set point. If water is not being circulated through the coil but the pump is running, then open the air bleed valve in the unit and purge any air left in the system.
6. Adjust the water heater thermostat so that the water temperature entering the hot water coil is 120 to 180 degrees depending on the amount of heat required by the structure. This is done with the unit energized and operating long enough for all temperatures to stabilize.

### **FILTER REPLACEMENT**

An air filter can restrict the airflow of air to the fan coil if it is not cleaned or replaced periodically. When replacing the air filter, always replace with the same type and size as originally furnished with the unit.

### **PUMP REPLACEMENT**

1. Disconnect electrical power to the unit before servicing.
  2. Remove access door to reveal pump. Close supply valve ("A") and return valve ("B"). Open the air bleed valve to de-pressurize the system and drain water.
  3. Remove the metal pump housing by loosening the four screws on the pump. **DO NOT UN-SOLDER PUMP.**
  4. Replace the new pump housing assembly and reconnect components to the pump. Before assembling, make sure that the rubber on the o-ring is in place on the pump housing.
- Purge the system of air as described earlier and reconnect the electrical power.

### **COMMON PROBLEMS & SOLUTIONS**

#### **•NOISY PUMP:**

System may not be totally purged of air. Purge the system again as described earlier.

#### **•T & P VALVE ON WATER HEATER WEEPS:**

This normally occurs when a backflow preventer has been installed in the cold water line supplying the water heater. An expansion tank may be necessary to correct the problem. Contact a qualified plumbing professional for assistance.

#### **•HOT WATER IS CIRCULATING THROUGH THE HEATING COIL DURING THE COOLING CYCLE:**

The check valve may be stuck open and allowing hot water to circulate through the coil.

#### **•LITTLE OR NO HEAT FROM WATER COIL:**

- A. Purge the system.
- B. The inlet and outlet connections may be reversed at the fan coil.
- C. Water heater thermostat is not set at proper temperature.
- D. Water heater thermostat is not calibrated.
- E. The dip tube in the water heater may not be installed correctly or may be restricted.
- F. Look for restriction in heating system from water heater to fan coil. Because some water heaters are supplied with check valves, remove any extra check valves except for the one supplied with the fan coil.
- G. The air handler is undersized for the space being heated.
- H. Water heater is undersized.

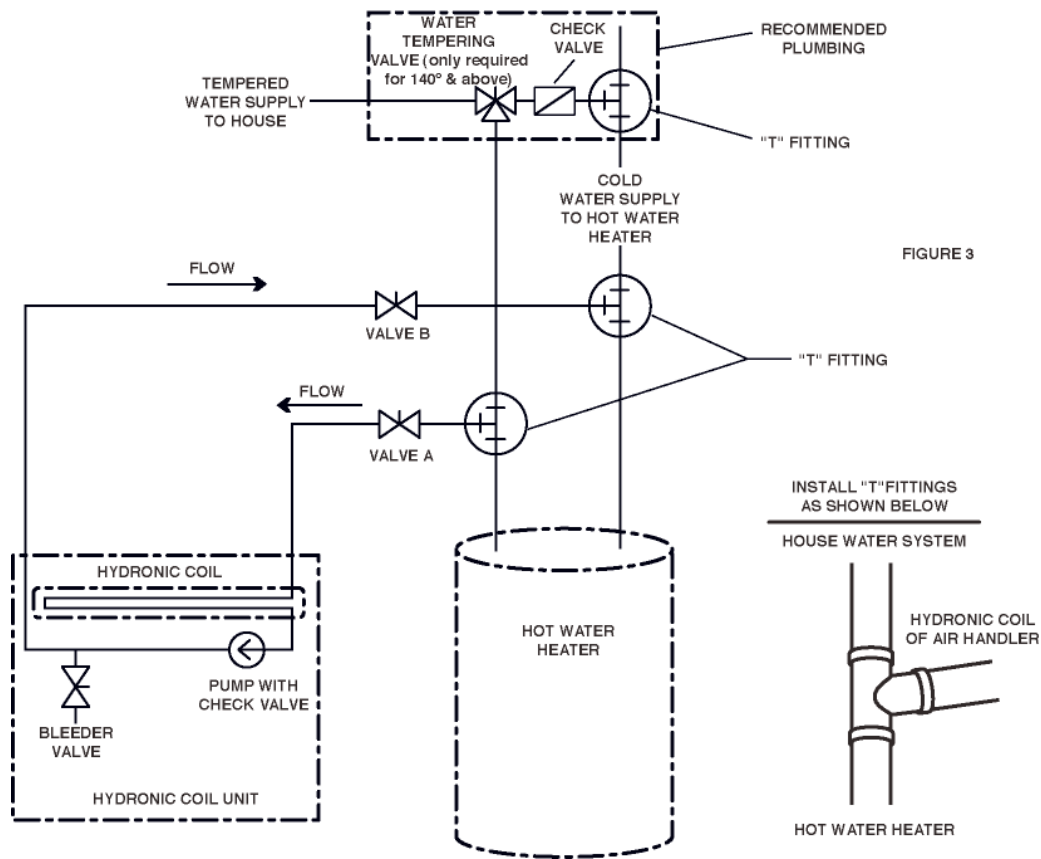

FIGURE 3

## Equipment Sizing

### Air Handler Selection:

Select an air handler with a heating output that exceeds the space heating loss of the structure and that has a cooling coil sized to match the outdoor condensing unit. Special note... the heating output of the air handler or hot water coil will not be greater than the output of the selected hot water heater. Therefore, if the water heater is undersized the heating BTUH of the air handler will be LESS than it's rated output.

### Water Heater Selection:

The following sizing information should only be used as a basic guide to adequate water heater sizing because of variations in each family's domestic hot water requirements. For additional assistance in water heater sizing contact a professional engineer.

Proper water heater sizing should consider both the gallon capacity AND the BTU input of the water heater.

#### a. To determine water heater GALLON CAPACITY:

A minimum 40-gallon high recovery and/or high efficiency gas or oil-fired water heater is recommended. The following volume-sizing guide is satisfactory in most areas of the country:

600-800 CFM air handlers- minimum 40-gallon water heater

1000-1200 CFM air handlers- minimum 50-gallon water heater

1400-1600 CFM air handler-either two 40-gallon water heaters piped together, one high input 50 gallon (63,000 to 75,000 BTU input), or one 72 to 75 gallon.

2000 CFM air handler- any combination of water heaters having at least 105,000 BTU OUTPUT.

#### b. To determine water heater BTU INPUT: (assumes a water heater recovery efficiency of 76%)

For mild climates:  $BTU\ INPUT = \text{structure's heat loss} \times 1.51$

For colder climates:  $BTU\ INPUT = \text{structure's heat loss} \times 1.58$

Note: All units installed in Massachusetts are required to be in compliance with CMR 248 Massachusetts State Plumbing Code and/or Massachusetts Fuel Gas Code.

These codes require the use of an optional pump timer to circulate the hydronic loop independent of the thermostat.

**WIRE HARNESS**  
127031  
127034  
127037

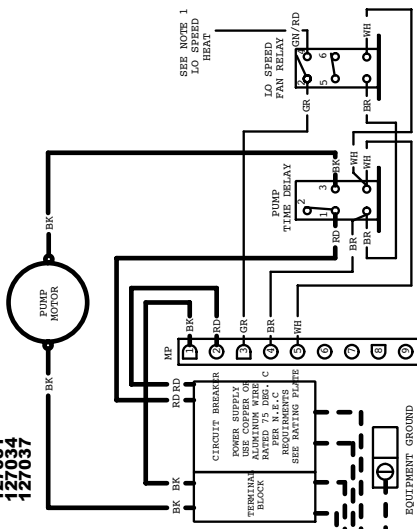

WXXSP-000 UXXSP-000  
WXXLP-000 UXXLP-000

**WIRE HARNESS**  
127031  
127034  
127037

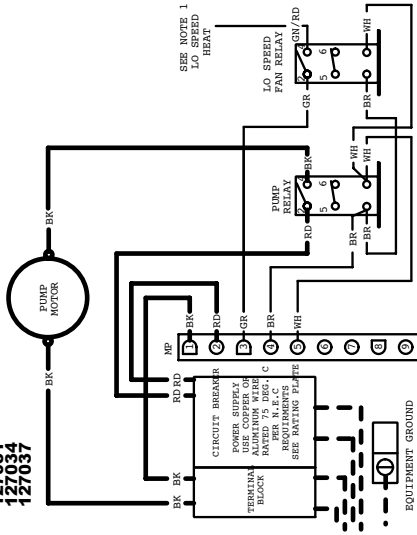

WXXSP-XXX UXXSP-XXX  
WXXLP-XXX UXXLP-XXX

**WIRE HARNESS**  
127031  
127034  
127037

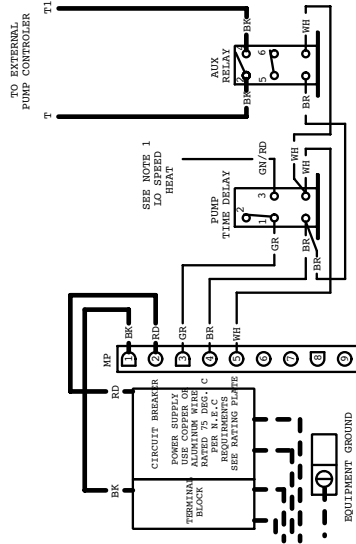

WXXSL-XXX UXXSL-XXX  
WXXLL-XXX UXXLL-XXX

**WIRE HARNESS**  
127028  
127029  
127038  
127039 (WITH NOTE 1)

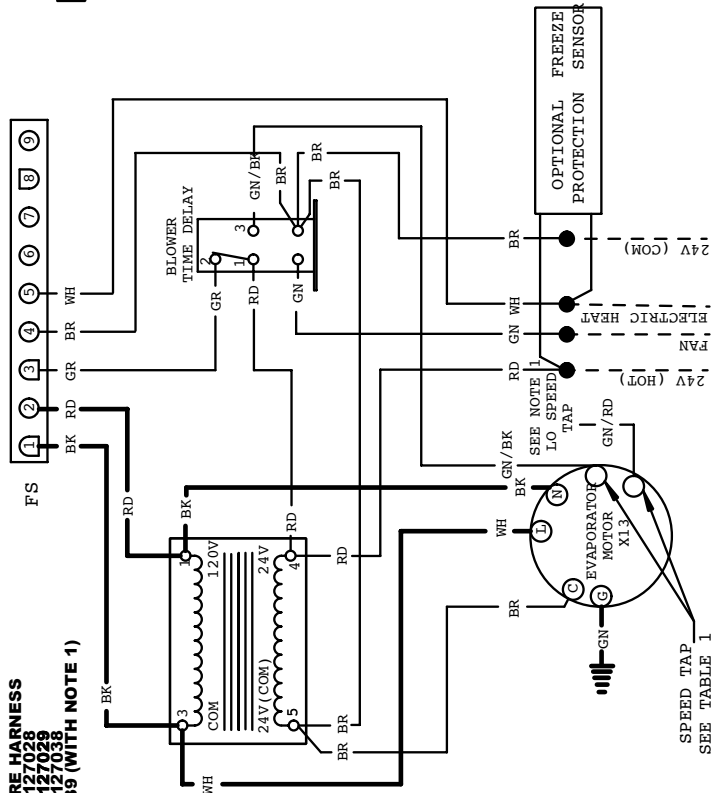

**NOTES :**

- FOR LOW SPEED HEAT SEE TABLE 1 (SPEED TAP LO).

TABLE 1  
X13 EM SPEED SETTING

UNIT MODEL	BTD TAP	FHR HTAP	SPEED LC	SPEED HI
AFM/W18	2	3	3	4
AFM/W24	1	2	2	4
AFM/W30	2	3	4	4
AFM/W36	1	2	2	4
AFM42	3	4	4	5
AFM48	2	3	3	5
AFM60	1	2	2	5

X13 PLUG WIRING

4	5	6	7	8	9
C	L	G	N		

SPEED TAPS

1	2	3	4	5
---	---	---	---	---

**LEGEND**

- BTD - BLOWER TIME DELAYEM - EVAPORATOR MOTOR
- PR - PUMP RELAY
- CB - CIRCUIT BREAKER
- EM - EVAPORATOR MOTOR HS - HEAT SEQUENCER
- F5 - FEMALE SOCKET
- TB - TERMINAL BLOCK

**COLOR CODE**

- W - WHITE
  - BK - BLACK
  - RD - RED
  - BK/W - BLACK/WHITE STRIPE
  - GN - GREEN
  - GR - GRAY
  - BR - BROWN
  - GN/BK - GREEN/BLACK STRIPE
  - GN/RD - GREEN/RED STRIPE
- WIRING CODE
- FACTORY HIGH VOLT
  - FACTORY LOW VOLT
  - FIELD HIGH VOLT
  - FIELD LOW VOLT

DIAGRAM # 101020A  
CURRENT 08/01/08