



373 ATASCOCITA RD. • HUMBLE, TX • 77396
TEL (281) 441-6500 • FAX (281) 441-6510
<< www.aspenmfg.com >>

INSTALLATION INSTRUCTIONS

FMB/FMC SERIES MULTI-POSITION AIR HANDLER



IMPORTANT MESSAGE TO INSTALLER: "The United States Environmental Protection Agency ("EPA") has issued various regulations regarding the introduction of disposal of refrigerants in this unit. Failure to follow these regulations may harm the environment and can lead to the imposition of substantial fines. Because these regulations may vary due to the passage of new laws we suggest that any work on this unit be done by a certified technician. Should you have any questions please contact the local office of EPA." Some Aspen coils may include a Schrader valve on the suction manifold. During installation, this Schrader valve must be protected from heat or it may leak. All Aspen coils are shipped with a nitrogen holding charge. DO NOT install the coil if this charge is not present.

IMPORTANT MESSAGE TO OWNER: These instructions should be carefully read and kept near product, for future reference. While these instructions are addressed primarily to the installer, useful maintenance information is included. Have your installing dealer acquaint you with the operating characteristics of the product and periodic homeowner maintenance requirements. As expressed in our product warranty, Aspen will not be billed for any structural damage due to failure to follow these installation requirements. Once installed, Aspen coils may contain chlorofluorocarbons (CFC's) or hydrochlorofluorocarbons (HCFC's). Under certain conditions, CFC's & HCFC's may pose a health risk. Please notify a licensed service technician immediately if you suspect your system may contain a leak.

CODES AND REGULATIONS

This product is designed and manufactured to permit installation in accordance with National Codes. It is the installer's responsibility to install the product in accordance with National Codes and/or prevailing local codes and regulations. The manufacturer assumes no responsibility for equipment installed in violation of any code or regulation.

INSPECTION

This product has been inspected and run tested at the factory and released to the transportation agency without known damage. Inspect exterior of carton for evidence of rough handling in shipment. Unpack carefully, if damage is found, report immediately to the transportation agency.

REPLACEMENT PARTS

Order all replacement parts through your local distributor. When ordering parts, give complete model and serial number as shown on the unit rating plate.

BLOWER DATA

MODEL	MOTOR SPEED	MOTOR HP	MOTOR VOLTAGE	CFM VS. EXTERNAL STATIC PRESSURE (1,2)					
				0.10	0.15	0.20	0.30	0.40	0.50
FMBXX - 18	LOW	0.20	240	890	875	860	845	810	(3)
FMBXX - 24/25	HIGH	0.20	240	1020	1005	990	975	939	(3)
FMBXX - 30	HIGH	0.33	240	1116	1094	1069	1010	960	(3)
FMBXX - 36/37	HIGH	0.33	240	1233	1203	1178	1121	1054	(3)
FMBXX - 38	MED	0.75	240	1518	1488	1458	1397	1332	1265
FMBXX - 42	LOW	0.75	240	1507	1500	1493	1470	1452	1431
FMBXX - 48	MED	0.75	240	1823	1806	1806	1782	1753	1717
FMBXX - 60/61	HIGH	0.75	240	2180	2160	2141	2081	2081	1989

- 1) Dry coil with filter in place
- 2) For 208v operation multiply by .90
- 3) Not rated

Model	A	B	C	D
FMB18-38	20	20	43.12	18 x 12
FMB42-61	27.5	21.5	52.25	19.5 x 15.5

INSTALLATION CLEARANCES		
TOP	OPERATION	SERVICE
	0"	0"
FRONT	0"	30"
SIDES	0"	0"
REAR	0"	0"

**INSTALLATION
PRODUCT LOCATION**

In an attic installation, where unit is resting on the floor, a suitable isolation pad should be provided to minimize equipment sound transmission to ceiling below. FURTHERMORE, IN ALL COOLING APPLICATIONS, A SECONDARY DRAIN PAN MUST BE PROVIDED BY THE INSTALLER AND PLACED UNDER THE ENTIRE UNIT WITH A SEPARATE DRAIN LINE PROPERLY SLOPED AND TERMINATED IN AN AREA VISABLE TO OWNER. THIS SECONDARY PAN CAN PROVIDE EXTRA PROTECTION TO THE AREA UNDER THE UNIT SHOULD THE PRIMARY DRAIN PLUG UP AND OVERFLOW. AS EXPRESSED IN OUR PRODUCT WARRANTY, ASPEN WILL NOT BE BILLED FOR ANY STRUCTURAL DAMAGE DUE TO THE FAILURE TO FOLLOW THIS INSTALLATION REQUIREMENT.

The furnace is completely serviceable from the front. All Units are approved for 0" clearance.

This Electric Furnace allows substantial freedom in positioning the product to best serve the structure requirements. Units may, without field modification, be positioned for up or right horizontal application. With field modification the air handler can be positioned for left horizontal application. See page 6 for detailed installation instructions. This air handler can also be used in the counter-flow application. See page 6 for details.

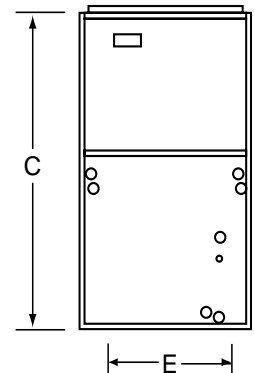
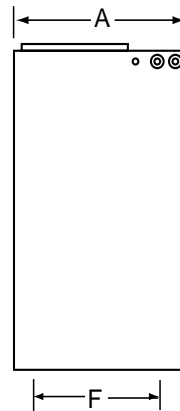
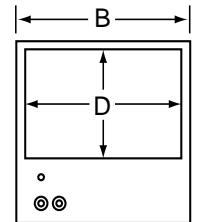

**HORIZONTAL
APPLICATION
IMPORTANT
INSTRUCTIONS**

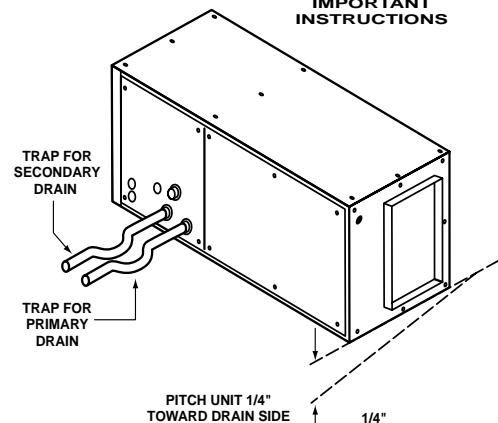

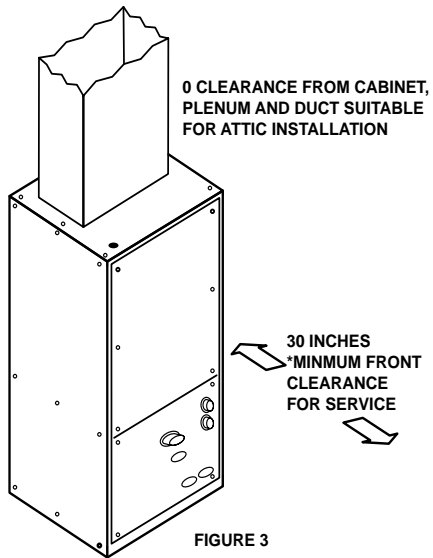

DUCT INSTALLATION

Air duct systems should be installed in accordance with standards for air conditioning systems, National Fire Protection Association Pamphlet No. 90A or 90B. They should be sized in accordance with National Environmental System Contractors Association Manual K, or whichever is applicable.

On any job, non-flammable flexible collars should be used for the return air and discharge connections to prevent transmission of vibration. Although these units have been specially designed for quiet vibration-free operation, air ducts can act as sound boards and could, if poorly installed, amplify the slightest vibration to the annoyance level.

All main supply and return air drops should be run full size as determined by the designer of the duct system and should not necessarily be the size of the duct flange openings of the unit

When installing a central air return grille in or near the living space, it is advisable to design the ductwork so that the grille is not in direct line with the opening in the unit. One or two elbows and acoustical duct liner will also assure a quieter installation and system.

It is recommended that wherever supply and return air sheet metal duct pass through unconditioned areas, they be insulated to prevent excessive heat loss during heating operation. When applied in conjunction with summer air conditioning, sheet metal duct routed through unconditioned areas should be insulated and have an outside vapor barrier to prevent formation of condensation.

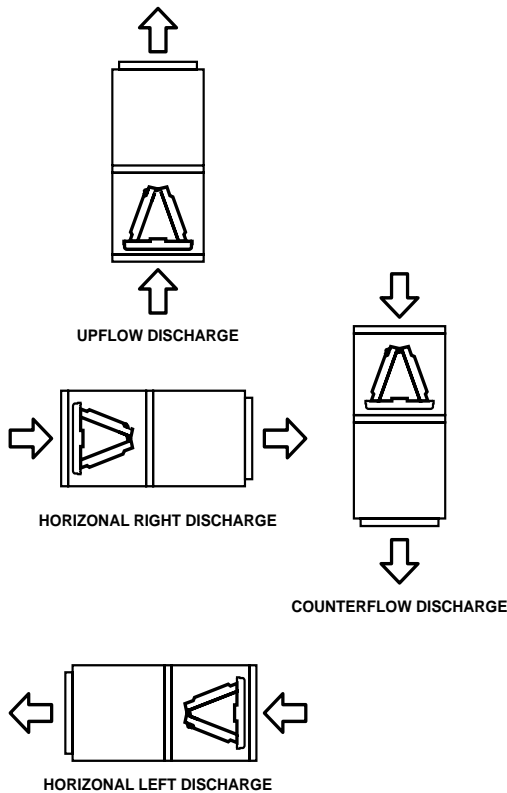
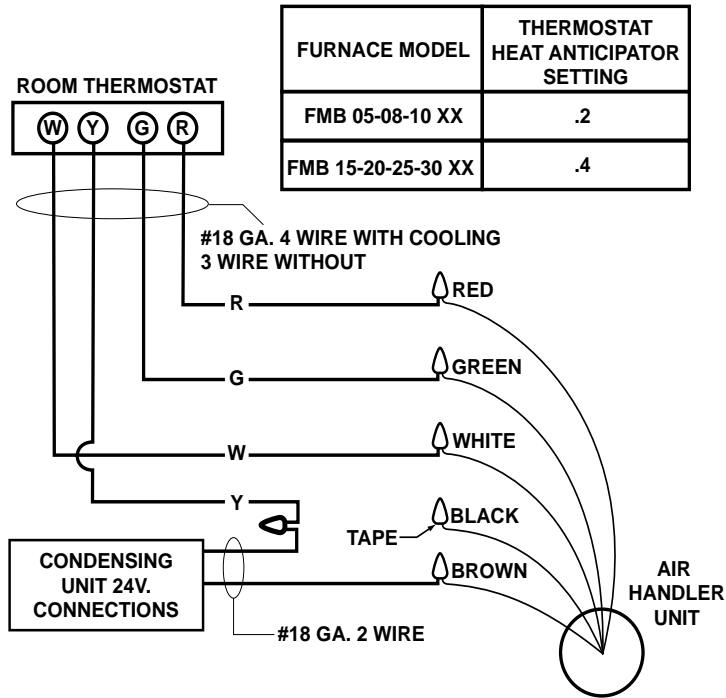

FIGURE 2

1 STAGE ELECTRIC



2 STAGE ELECTRIC

FURNACE MODEL	THERMOSTAT HEAT ANTICIPATOR SETTING		KW STAGES	
	2 STAGE T' STAT STAGE1	STAGE2	WHEN STAGING STAGE1	STAGE2
FMB15 XX	.2	.2	10.0 KW	5.0 KW
FMB20 XX	.2	.2	10.0 KW	10.0 KW
FMB25 XX	.2	.2	20.0 KW	5.0 KW
FMB30 XX	.2	.2	20.0 KW	10.0 KW

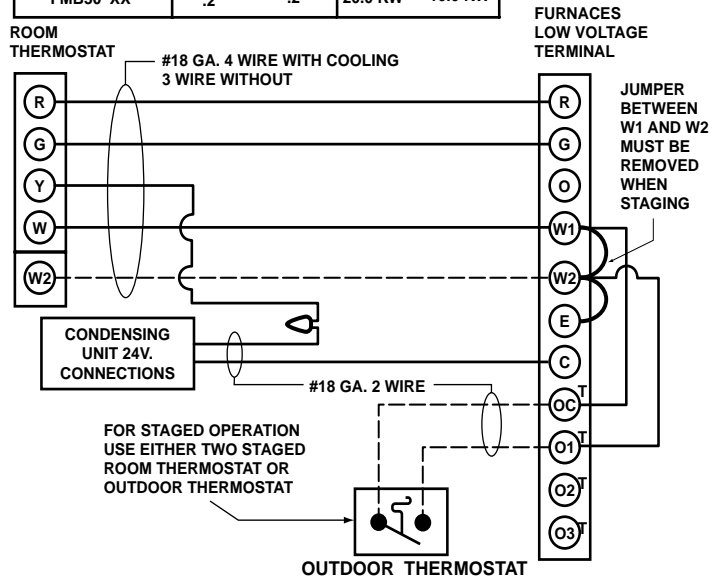

REFRIGERANT PIPING

Refrigerant piping should follow the recommended procedures set forth in the appropriate manual. Refrigerant piping exits the door. Consideration should be given to routing refrigerant lines during installation, so bottom door can be removed for access. Insulation on the suction line must extend into cabinet and continue as far as possible to eliminate condensation from dripping on to access door insulation.

REFRIGERANT PIPING

Refrigerant piping should follow the recommended procedures set forth in the appropriate manual. Refrigerant piping exits the door. Consideration should be given to routing refrigerant lines during installation, so bottom door can be removed for access. Insulation on the suction line must extend into cabinet and continue as far as possible to eliminate condensation from dripping on to access door insulation.

ELECTRICAL INSTALLATION

These units are designed for single or three phase 208/230 volt 60 Hertz power supply. Wire selection and wiring must be in accordance with the National Electric Code and/or local codes. Unit terminals are designed to accommodate copper and aluminum wiring. If aluminum wiring is used, please observe the special precautions relative to sizing, handling, wire connections and corrosion protection.

All models with 5, 8, or 10 KW electric heat are arranged for single circuit connection. Models larger than 10 KW are arranged for multi-circuit connection.

START UP

After all connections are made, start up and check out of the unit must be performed before proper evaluation of the entire system can be made. Make sure that heat anticipator is properly set as noted on low voltage wiring diagrams.

Load requirements can vary in each residence and it may be necessary for the installer or homeowner to make slight adjustments to the heat anticipator setting for longer or shorter cycles. It is recommended to change the setting no more than plus or minus .05 amp. at one time. Greater changes can cause the unit to rapid cycle or remain on excessively. To properly check the unit's operation, the installer should have an electrical current measuring device (0-10 amp Amprobe), air pressure measuring device (0-1.0 in slope gauge), and a temperature measuring device (0-200°F thermometer).

Install the amprobe to measure blower current, the slope gauge to measure static air pressure at the units and the temperature device to measure unit supply and return air temperature. Before taking measurements, be sure that all registers, grilles and dampers are open or are set to their proper positions. Be sure that clean filters are in place. Temperature measuring device must be installed to obtain average temperature at both inlet and outlet. For outlet, measure temperature of each main trunk at a location far enough away to avoid heater radiation and read the average temperatures.

A. ELECTRIC FURNACE

1. Turn on power supply. Set thermostat fan switch to on. Set the cooling indicator to maximum, heating to minimum. System switch may be on heat or cool. Check slope gauge measurement against appropriate air flow chart. Make damper, register and motor speed adjustments to obtain required airflow.
2. Set thermostat fan switch to auto, system to heat and thermostat heating indicator to maximum heat. Blower should start and all heat be energized.
3. Check air flow using temperature rise method.

$$CFM = \frac{OUTPUT (BTUH)}{1.08 \times TEMP RISE}$$

NOTE: BTUH output should be computed by VOLT x AMPS x 3.4 = BTUH OUTPUT. Since line volt can vary, do not use nameplate rating to determine output.

OPERATION AND MAINTENANCE

1) Room Thermostat- This is the device that controls that operation of your heating and/or cooling unit. It senses the indoor temperature and signals the equipment to start or stop maintaining the temperature you have selected for your comfort. The room thermostat should be in a central, draft free inside wall location for best operation. Do not place any heat producing apparatus such as lights, radio, etc., near the thermostat as this will cause erratic operation of the comfort system. The thermostat can accumulate dust or lint, which can affect its accuracy. It should be cleaned annually.

2) Air Filter(s)- All central air moving comfort systems must include air filter(s). These filters will be located either in the equipment or in the return air duct system upstream of the equipment. The filter(s) removes dust and debris from the air thus helping to keep your air conditioned space clean. More important, the filter keeps dust and debris from collecting on the heat transfer surfaces thus maintaining optimum equipment efficiency and performance. Inspect and clean or replace filters every month. This routine maintenance procedure will pay big dividends in reduced operating cost and reduced service expense. Never operate comfort equipment without filter(s).

3) Fuses and/or Circuit Breakers- This comfort equipment should be connected to the building electric service in accordance with local and National Electric codes. This electrical connection will include over current protection in the form of circuit breakers. Have your contractor identify the circuits and the location of over current protection so that you may be in a position to make inspections or replacements in the event the equipment fails to operate.

4) WARNING

- A) Do not store combustible materials or use gasoline or other flammable liquids or vapors in the vicinity of this appliance.
- B) Do not operate the comfort equipment with panels removed.
- C) Have your contractor point out and identify the various cut-off devices, switches, etc., that serve your comfort equipment. There is a main switch that will cut off energy to your heating system. Know where they are so that you may cut off the flow of energy in the event of overheating.

5) Periodic Checkup and Service- This product is designed to provide many years of dependable, trouble-free comfort when properly maintained. Proper maintenance will consist of annual check-ups and cleaning of the internal electrical and heat transfer components by a qualified service technician. Failure to provide periodic checkup and cleaning can result in excessive operating cost and/or equipment malfunction.

6) Lubrication- Direct drive blower motors are equipped with permanently lubricated bearings and do not require further lubrication.

LEFT HAND HORIZONTAL CONVERSION

NOTE: THE USE OF THE EXISTING HORIZONTAL DRAIN PAN ELIMINATES THE USE OF ANY DRAIN PAN KITS

1) To convert standard upflow air handler to left horizontal application, remove both upper/lower access panels and A-coil assembly from air handler cavity.

2) Place A-coil assembly inside horizontal drain pan towards left hand side and carefully slide into the air handler cavity. NOTE: Push coil pan assembly all the way to the rear of the air handler unit until the pan slips under the channel shape bracket in the rear. Reinstall upper and lower access panels in its normal position.

3) Condensate Drain Piping- "in all cooling applications, a secondary drain pan should be provided by the installer and placed under the entire unit with a separate drain line properly sloped and terminated in an area visible to the owner" As expressed in our product warranty, Aspen will not be billed for any

structural damage due to the failure to follow this installation requirement.

SPECIAL INSTRUCTIONS FOR COUNTER-FLOW APPLICATIONS(for units to be used in counter-flow application, order 2 each of p/n 125076 for FMB18-38 and p/n 125077 for FMB42-61)

(FMB-ELECTRIC FURNACE)

The FMB Series Electric Furnace is specifically designed for the use in the upflow, horizontal and counterflow positions. Should the application be for counterflow position, the following steps should be taken:

- 1) Before putting the air handler in the counterflow position, remove both access panels and remove the A-coil assembly and horizontal drain pan from the air handler cavity. Horizontal drain pan is not required for counterflow applications and can be discarded.
- 2) Turn the air handler to the counterflow position and install the counterflow coil brackets.
- 3) Slide the A-coil assembly into air handler and re-install both access panels.
- 4) The "FMB" coils are shipped with a check flowrator for use with either cooling or heat pump outdoor section on each unit.
- 5) Some units are supplied with factory-installed circuit breakers. If the air handler has circuit breakers, they must be snapped out of the factory-installed bracket and inverted to reflect "up" as the "on" position and "down" as the "off" position.

6) The above procedure should be done at the job site as the unit is not designed to be shipped in the counterflow mode.

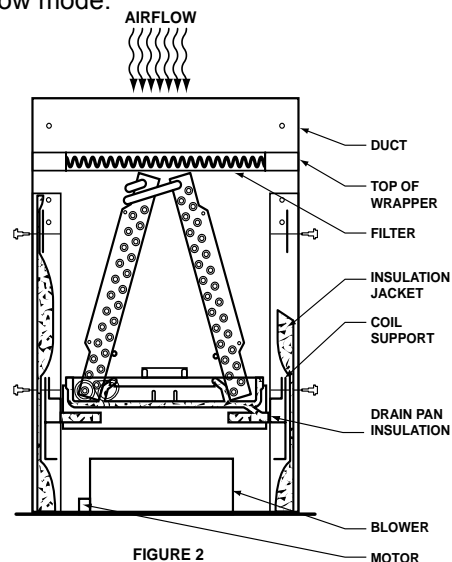

FIGURE 2