



373 ATASCOCITA RD. • HUMBLE, TX • 77396  
TEL (281) 441-6500 • FAX (281) 441-6510  
<< www.aspenmfg.com >>

# INSTALLATION INSTRUCTIONS

## FTB SERIES VERTICAL WALL MOUNT AIR HANDLER

**IMPORTANT MESSAGE TO INSTALLER:** "The United States Environmental Protection Agency ("EPA") has issued various regulations regarding the introduction of disposal of refrigerants in this unit. Failure to follow these regulations may harm the environment and can lead to the imposition of substantial fines. Because these regulations may vary due to the passage of new laws we suggest that any work on this unit be done by a certified technician. Should you have any questions please contact the local office of EPA." Some Aspen coils may include a Schrader valve on the suction manifold. During installation, this Schrader valve must be protected from heat or it may leak. All Aspen coils are shipped with a nitrogen holding charge. DO NOT install the coil if this charge is not present.

**IMPORTANT MESSAGE TO OWNER:** These instructions should be carefully read and kept near product, for future reference. While these instructions are addressed primarily to the installer, useful maintenance information is included. Have your installing dealer acquaint you with the operating characteristics of the product and periodic homeowner maintenance requirements. As expressed in our product warranty, Aspen will not be billed for any structural damage due to failure to follow these installation requirements. Once installed, Aspen coils may contain chlorofluorocarbons (CFC's) or hydrochlorofluorocarbons (HCFC's). Under certain conditions, CFC's & HCFC's may pose a health risk. Please notify a licensed service technician immediately if you suspect your system may contain a leak.

### CODES AND REGULATIONS

This product is designed and manufactured to permit installation in accordance with National Codes. It is the installer's responsibility to install the product in accordance with National Codes and/or prevailing local codes and regulations. The manufacturer assumes no responsibility for equipment installed in violation of any code or regulation.

### INSPECTION

This product has been inspected and run tested at the factory and released to the transportation agency without known damage. Inspect exterior of carton for evidence of rough handling in shipment. Unpack carefully, if damage is found, report immediately to the transportation agency.

### REPLACEMENT PARTS

Order all replacement parts through your local distributor. When ordering parts, give complete model and serial number as shown on the unit rating plate.

### INSTALLATION

These units are designed to be installed on top of a water heater or recessed into a wall in vertical upflow position. If these units are recessed in a wall, to attach units to the 2"X4" framing studs along the front flange. The front access panel should be removed and discarded when using the accessory grille shown in Figure1. These air handlers are also provided with an offset hanging bracket at the rear for certain wall mount applications. These models have a bottom or front return. Discard the drain access panel in the bottom of the unit if this is a bottom return application. If this is a front return application, the front access panel should be removed and discarded. A filter rack is provided for 1"X16"X16" nominal size filter. Inspect and clean or replace filters every month. These units are equipped with a bottom primary and secondary drain and a single side primary or secondary. When utilizing a unit disable switch on the secondary line, it must be located on the side connection to avoid a false shutdown created by condensate droplets falling into the bottom secondary connection. It should be adjusted to permit normal operation of the unit and disable the unit in the event of a clogged primary before the condensate spills over the pan. In lieu of this, a hood may be field fabricated to slide over the secondary to keep droplets out but allow trapped condensate into the secondary fitting. ALL DRAINS MUST BE TRAPPED OR SEALED SINCE COIL IS UPSTREAM OF THE BLOWER. FAILURE TO INSTALL A TRAP WILL RESULT IN CONDENSATION OVERFLOWING THE DRAIN PAN. ASPEN WILL NOT BE BILLED FOR ANY DAMAGE RESULTING FROM FAILURE TO FOLLOW THESE INSTRUCTIONS.

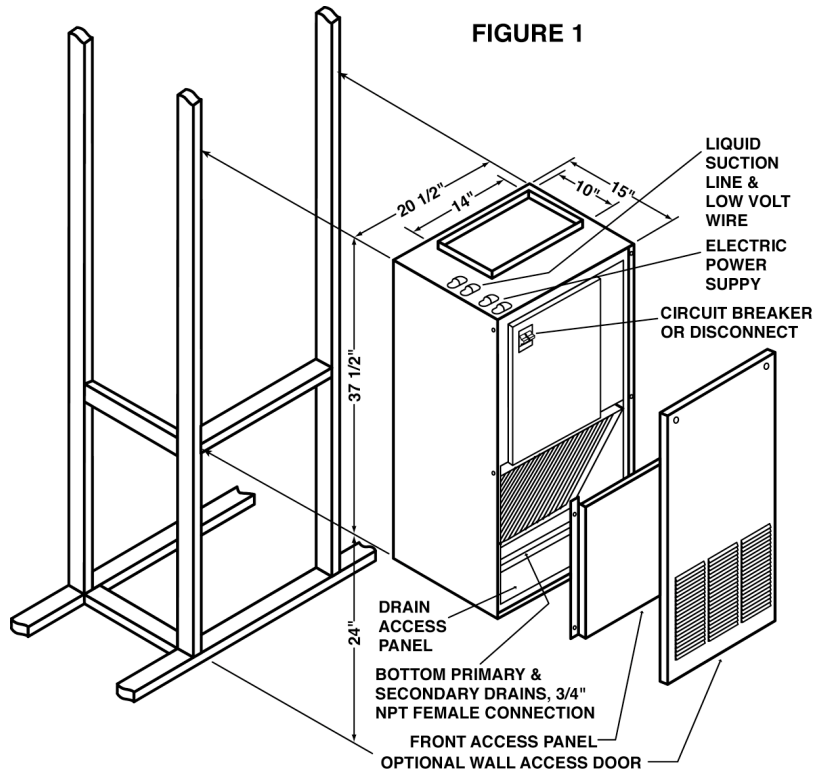

### ELECTRICAL INSTALLATION

