

DIMENSIONS AND SPECIFICATIONS

Aspen BB Series Horizontal Coils with Ductboard Plenums

Designed to Fit Amana GUVA Upflow/Horizontal Furnaces

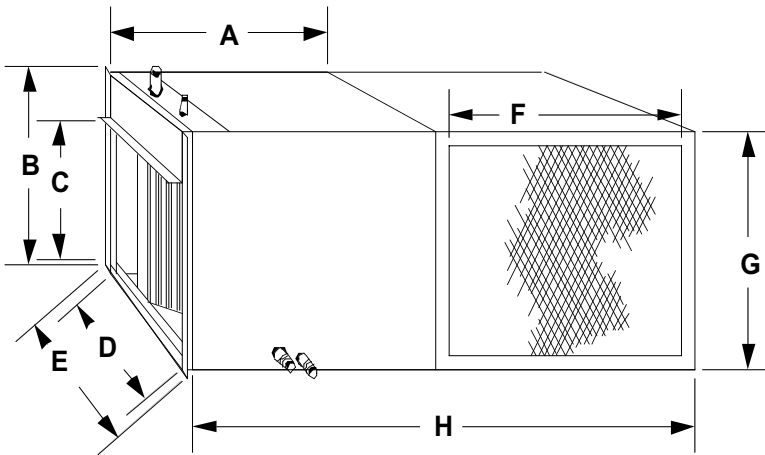

COIL SPECIFICATIONS

(Representative drawing only. Some models may vary in appearance.)

- ¥ Standard refrigerant connections: liquid line - 3/8" ODS, suction line - 7/8" ODS
- ¥ Refrigerant lines exit from the top of the coil.
- ¥ Four 3/4" FPT galvanized condensate drains (two per side).
- ¥ Powder-painted galvanized steel drain pan.
- ¥ Inlet and outlet dimensions are identical (without end caps).
- ¥ Five-year warranty.
- ¥ Flowrate standard. Factory or field-installable TXV available.
- ¥ Top access panel for easy service.
- ¥ Every coil immersion-tested at 500 psi, then nitrogen-pressurized and sealed.
- ¥ Rifled copper tubing, enhanced aluminum fins.
- ¥ ARI certifiable with all brands of A/C and heat pump systems.
- ¥ ETL listed.

OPTIONAL PLENUM SPECIFICATIONS

- ¥ Slips over either end of coil.
- ¥ Rectangular shape offers maximum surface area for duct connections.
- ¥ Plenum sides and top constructed of foil-backed fiberglass ductboard or sheet metal.
- ¥ Plenum end and bottom constructed of galvanized steel.

AMANA FURNACE MODEL	COIL + PLENUM MODEL	END CAP MODEL	COIL OVERALL		COIL INLET (END CAPS INSTALLED)		COIL WIDTH E	PLENUM		COIL + PLEN SIZE H	WT (LBS)
			A	B	C	D		F	G		
GUVA045__30	BBL 24+PLL 24	AMAN01	22-3/4	16-3/4	16-1/2	20-1/4	22	17-3/4	16-7/8	40	46
	BBL 30+PLL 30	AMAN01	22-3/4	16-3/4	16-1/2	20-1/4	22	17-3/4	16-7/8	40	46
	BBL 36+PLL 36	AMAN01	22-3/4	16-3/4	16-1/2	20-1/4	22	17-3/4	16-7/8	40	50
	BBH 37+PLH 37	AMAN05	22-3/4	20-3/4	16-1/2	20-1/4	22	17-3/4	20-7/8	40	70
	BBL 48+PLL 48	AMAN02	22-3/4	18-3/4	16-1/2	20-1/4	22	17-3/4	18-7/8	40	51
	BBH 49+PLH 49	AMAN06	22-3/4	18-3/4	16-1/2	20-1/4	22	17-3/4	18-7/8	40	72
GUVA070__40	BBH 48+PLH 48	AMAN03	22-3/4	22-3/4	20-1/2	20-1/4	22	17-3/4	22-7/8	40	56
	BBL 60+PLL 60	AMAN03	22-3/4	22-3/4	20-1/2	20-1/4	22	17-3/4	22-7/8	40	73
	BBL 61+PLL 61	AMAN03	22-3/4	22-3/4	20-1/2	20-1/4	22	17-3/4	22-7/8	40	75
	BBH 63+PLH 63	AMAN03	22-3/4	22-3/4	20-1/2	20-1/4	22	17-3/4	22-7/8	40	73
GUVA090__50	BBH 60+PLH 60	AMAN04	22-3/4	26-3/4	24-1/2	20-1/4	22	17-3/4	26-7/8	40	61
GUVA115__50	BBH 61+PLH 61	AMAN04	22-3/4	26-3/4	24-1/2	20-1/4	22	17-3/4	26-7/8	40	78
	BBH 65+PLH 65	AMAN04	22-3/4	26-3/4	24-1/2	20-1/4	22	17-3/4	26-7/8	40	85