

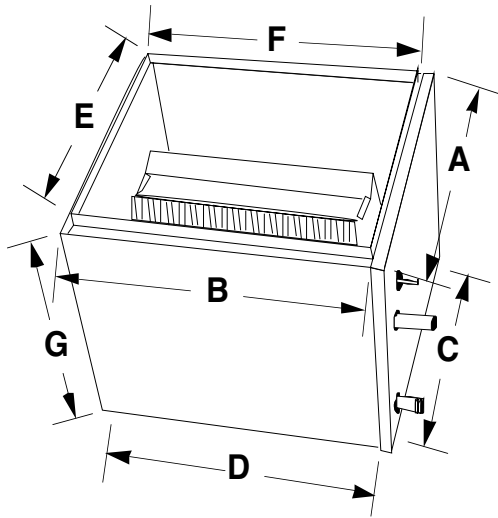

DIMENSIONS AND SPECIFICATIONS

Aspen Cased Upflow Coils

Designed for American Standard CUB-A Upflow Furnaces



GENERAL SPECIFICATIONS

- Standard refrigerant connections: liquid line - 3/8" ODS, suction line - 7/8" ODS
- Left-hand refrigerant and plumbing connections.
- One 3/4" MPT condensate drain.
- Powder-painted metal drain pan. Stainless available.
- Five-year warranty.
- Flowrater standard. Factory or field-installable TXV available.
- Front access panel for easy service.
- Every coil immersion-tested at 500 psi, then nitrogen-pressurized and sealed.
- Heavy gauge embossed galvanized cabinets fully lined with 1/2" faced insulation.
- Flush-fits furnace in most applications.
- Rifled copper tubing, enhanced aluminum fins.
- ARI certifiable with all brands of A/C and heat pump systems.
- ETL listed.

AMERICAN STANDARD FURNACE MODEL	ASPEN COIL MODEL	SUFFIX	FOOTPRINT		BOTTOM OPENING		TOP OPENING		HT
			A	B	C	D	E	F	G
CUB040A924A CUB060A936A	BVR** 24	A4Q16	14-1/2	21-3/8	13-1/2	19-7/8	13	19-7/8	16
	BV1** 24	A4Q16	14-1/2	21-3/8	13-1/2	19-7/8	13	19-7/8	16
	BVR** 30	A4Q16	14-1/2	21-3/8	13-1/2	19-7/8	13	19-7/8	16
	BV1** 30	A4Q16	14-1/2	21-3/8	13-1/2	19-7/8	13	19-7/8	16
CUB080A936A CUB080A948A CUB100A936A	BVR** 30	A4R18	17-1/2	21-3/8	16-1/2	19-7/8	16	19-7/8	18
	BV1** 30	A4R18	17-1/2	21-3/8	16-1/2	19-7/8	16	19-7/8	18
	BVR** 36	A4R18	17-1/2	21-3/8	16-1/2	19-7/8	16	19-7/8	18
	BV5** 36	A4R18	17-1/2	21-3/8	16-1/2	19-7/8	16	19-7/8	18
	BVR** 42	A4R18	17-1/2	21-3/8	16-1/2	19-7/8	16	19-7/8	18
	BV5** 42	A4R24	17-1/2	21-3/8	16-1/2	19-7/8	16	19-7/8	24
	BVR** 48	A4R24	17-1/2	21-3/8	16-1/2	19-7/8	16	19-7/8	24
	BV1** 48	A4R24	17-1/2	21-3/8	16-1/2	19-7/8	16	19-7/8	24
CUB100A948A CUB100A960A	BVR** 42	A4S20	21	21-3/8	20	19-7/8	19-1/2	19-7/8	20
	BV5** 42	A4S20	21	21-3/8	20	19-7/8	19-1/2	19-7/8	20
	BVR** 48	A4S20	21	21-3/8	20	19-7/8	19-1/2	19-7/8	20
	BV1** 48	A4S26	21	21-3/8	20	19-7/8	19-1/2	19-7/8	26
	BV5** 48	A4S26	21	21-3/8	20	19-7/8	19-1/2	19-7/8	26
	BV1** 60	A4S26	21	21-3/8	20	19-7/8	19-1/2	19-7/8	26
	BV7** 60	A4S26	21	21-3/8	20	19-7/8	19-1/2	19-7/8	26
	BV2** 60	ATA26	21	23	20	19-7/8	19-1/2	21-1/2	26
CUB120A960A CUB140A960A	BV1** 60	A4T26	24-1/2	21-3/8	23-1/2	19-7/8	23	19-7/8	26
	BV7** 60	A4T26	24-1/2	21-3/8	23-1/2	19-7/8	23	19-7/8	26
	BV2** 60	A4W26	24-1/2	23	23-1/2	19-7/8	23	21-1/2	26

BV Spec-American Standard A. Effective 5/16/00. Supersedes all previous versions. Subject to change without notice.