

DIMENSIONS AND SPECIFICATIONS

Aspen Cased Upflow Coils

Designed for Arcoaire and Comfortmaker GNJ and GUM Series Furnaces

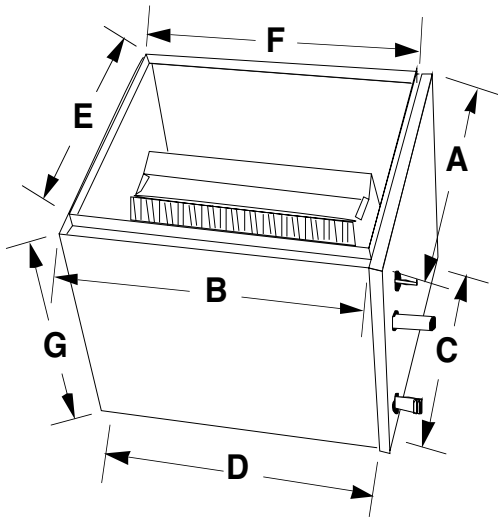

GENERAL SPECIFICATIONS

- Standard refrigerant connections: liquid line - 3/8" ODS, suction line - 7/8" ODS
- **Center-front refrigerant and plumbing connections.**
- One 3/4" MPT condensate drain.
- Powder-painted metal drain pan. Stainless available.
- Five-year warranty.
- Flowrater standard. Factory or field-installable TXV available.
- Front access panel for easy service.
- Every coil immersion-tested at 500 psi, then nitrogen-pressurized and sealed.
- Heavy gauge embossed galvanized cabinets fully lined with 1/2" faced insulation.
- Flush-fits furnace in most applications.
- Rifled copper tubing, enhanced aluminum fins.
- ARI certifiable with all brands of A/C and heat pump systems.
- ETL listed.

FURNACE MODEL	COIL MODEL	SUFFIX	FOOTPRINT		BOTTOM OPENING		TOP OPENING		HEIGHT
			A	B	C	D	E	F	
GNJ050A012 GNJ075A012	BV1** 24	A4M14	15-1/2	21	14-1/4	18-3/4	14	19-1/2	14
	BVR** 24	A4M14	15-1/2	21	14-1/4	18-3/4	14	19-1/2	14
	BV1** 30	A4M18	15-1/2	21	14-1/4	18-3/4	14	19-1/2	18
	BVR** 30	A4M14	15-1/2	21	14-1/4	18-3/4	14	19-1/2	14
	BV5** 36	A4M18	15-1/2	21	14-1/4	18-3/4	14	19-1/2	18
	BVR** 36	A4M18	15-1/2	21	14-1/4	18-3/4	14	19-1/2	18
GNJ075A016 GNJ100A012 GNJ100A016 GUM050 GUM075	BV1** 24	A4N14	19-1/8	21	17-7/8	18-3/4	17-5/8	19-1/2	14
	BVR** 24	A4N14	19-1/8	21	17-7/8	18-3/4	17-5/8	19-1/2	14
	BV1** 30	A4N18	19-1/8	21	17-7/8	18-3/4	17-5/8	19-1/2	18
	BVR** 30	A4N14	19-1/8	21	17-7/8	18-3/4	17-5/8	19-1/2	14
	BV5** 36	A4N18	19-1/8	21	17-7/8	18-3/4	17-5/8	19-1/2	18
	BVR** 42	A4N22	19-1/8	21	17-7/8	18-3/4	17-5/8	19-1/2	22
	BV5** 42	A4N22	19-1/8	21	17-7/8	18-3/4	17-5/8	19-1/2	22
	BV1** 48	A4N26	19-1/8	21	17-7/8	18-3/4	17-5/8	19-1/2	26
GNJ100A020 GNJ125A020 GNJ150A020 GUM100	BVR** 36	A4P22	22-3/4	21	21-1/2	18-3/4	21-1/4	19-1/2	22
	BV5** 36	A4P22	22-3/4	21	21-1/2	18-3/4	21-1/4	19-1/2	22
	BVR** 42	A4P22	22-3/4	21	21-1/2	18-3/4	21-1/4	19-1/2	22
	BV5** 42	A4P22	22-3/4	21	21-1/2	18-3/4	21-1/4	19-1/2	22
	BV1** 48	A4P26	22-3/4	21	21-1/2	18-3/4	21-1/4	19-1/2	26
	BV5** 48	A4P22	22-3/4	21	21-1/2	18-3/4	21-1/4	19-1/2	22
	BV1** 60	A4P26	22-3/4	21	21-1/2	18-3/4	21-1/4	19-1/2	26
	BV2** 60	AHA26	22-3/4	23	21-1/2	18-3/4	21-1/4	21-1/2	26
GUM125	BV2** 60	A4X26	26-3/4	23	25-1/8	18-3/4	25-1/4	21-1/2	26
	BV1** 60	A4Y26	26-3/4	21	25-1/8	18-3/4	25-1/4	19-1/2	26