

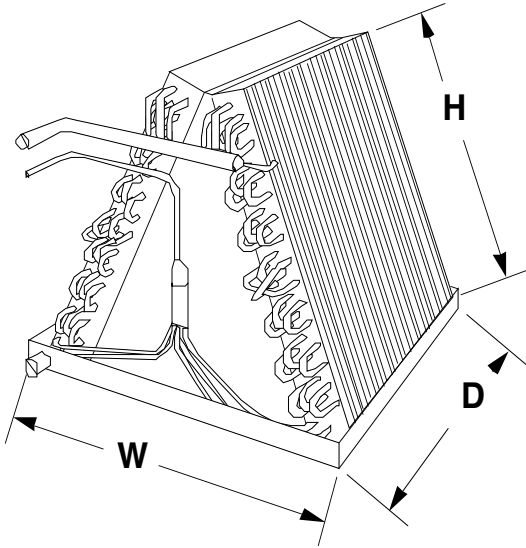

## DIMENSIONS AND SPECIFICATIONS Aspen Upflow/Downflow Uncased Coils



### GENERAL SPECIFICATIONS

- Standard refrigerant connections: liquid line - 3/8" ODS, suction line - 7/8" ODS
- Left-hand refrigerant and plumbing connections.
- One 3/4" MPT condensate drain.
- Powder-painted metal drain pan. Stainless available.
- Five-year warranty.
- Flowrater standard. Factory or field-installable TXV available.
- Front access panel for easy service.
- Every coil immersion-tested at 500 psi, then nitrogen-pressurized and sealed.
- Rifled copper tubing, enhanced aluminum fins.
- ARI certifiable with all brands of A/C and heat pump systems.
- ETL listed.

COIL MODEL	BARE COIL HT (H)	DRAIN PAN DIMENSIONS (W / D)							
		13-1/2 X 19	14-3/4 X 19	15-3/4 X 19	16-3/4 X 19	18-1/2 X 19	19-1/4 X 19	20-1/4 X 19	21-1/4 X 19
BV1**24	12	Z10*	Z11	Z12	Z13				
BVR**24	10	Z10*	Z11	Z12	Z13				
BV1** 30	14	Z10*	Z11	Z12	Z13				
BVR** 30	12	Z10*	Z11	Z12	Z13				
BV5** 36	16				Z14*	Z15	Z16	Z17	Z18
BVR** 36	14				Z14*	Z15	Z16	Z17	Z18
BV5** 42	18				Z14*	Z15	Z16	Z17	Z18
BVR** 42	16				Z14*	Z15	Z16	Z17	Z18

\* For use with two row coils only.

COIL MODEL	BARE COIL HT (H)	DRAIN PAN DIMENSIONS (W / D)									
		22-3/4 X 19	23-1/2 X 19	24-1/2 X 19	25-3/4 X 19	26-1/4 X 19	22-3/4 X 22-1/2	23-1/2 X 22-1/2	24-1/2 X 22-1/2	25-3/4 X 22-1/2	26-1/4 X 22-1/2
BV1** 48	22	Z19	Z20	Z21	Z22	Z23					
BV5** 48	20	Z19	Z20	Z21	Z22	Z23					
BVR** 48	18	Z19	Z20	Z21	Z22	Z23					
BV1** 60	22	Z19	Z20	Z21	Z22	Z23					
BV2** 60	24						Z24	Z25	Z26	Z27	Z28
BV7** 60	24	Z19	Z20	Z21	Z22	Z23					

BV Spec-L/C. Effective 9/10/02. Supersedes all previous versions. Subject to change without notice.