

DIMENSIONS AND SPECIFICATIONS

Aspen Upflow/Downflow Uncased Chilled Water Coils

GENERAL SPECIFICATIONS

- Left-hand refrigerant and plumbing connections.
- One 3/4" MPT condensate drain.
- Powder-painted metal drain pan. Stainless available.
- Five-year warranty.
- Every coil immersion-tested at 500 psi, then nitrogen-pressurized and sealed.
- Rifled copper tubing, enhanced aluminum fins.
- ETL listed.

COIL MODEL	BARE COIL HEIGHT (H)	DRAIN PAN WIDTH (W)	DRAIN PAN DEPTH (D)	FITTINGS
KBW 24	10	12-7/8	20-5/8	7/8 S X 3/4 FPT

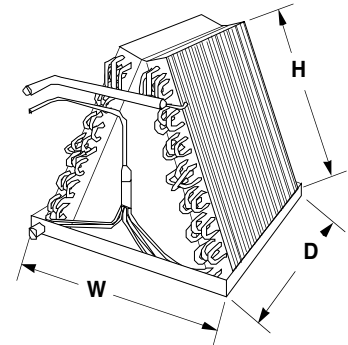

COIL MODEL	BARE COIL HEIGHT (H)	DRAIN PAN WIDTH (W)	DRAIN PAN DEPTH (D)	FITTINGS
KBW 36	16	20-5/8	20-5/8	7/8 S X 1 FPT
KBW 48	16	24-5/8	20-5/8	7/8 S X 1 FPT
KBW 60	16	29-3/4	20-5/8	7/8 S X 1/1/4 FPT

