

DIMENSIONS AND SPECIFICATIONS

Aspen Uncased Coils

Designed for Canadian Applications

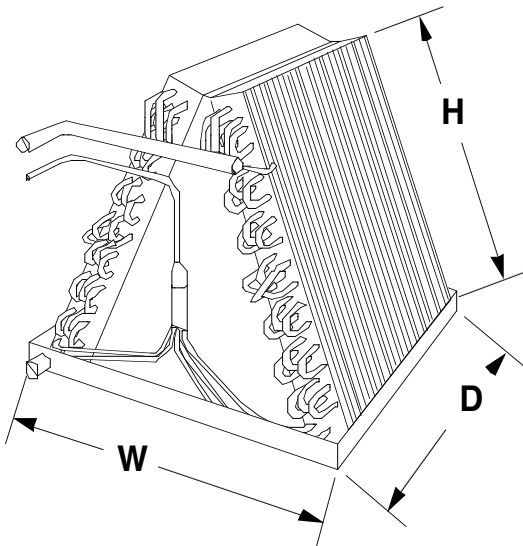

GENERAL SPECIFICATIONS

- Standard refrigerant connections: liquid line - 3/8" ODS, suction line - 7/8" ODS
- Left-hand refrigerant and plumbing connections.
- One 3/4" MPT condensate drain.
- Powder-painted metal drain pan. Stainless available.
- Five-year warranty.
- Flowrater standard. Factory or field-installable TXV available.
- Front access panel for easy service.
- Every coil immersion-tested at 500 psi, then nitrogen-pressurized and sealed.
- Rifled copper tubing, enhanced aluminum fins.
- ARI certifiable with all brands of A/C and heat pump systems.
- ETL listed.

MODEL NUMBER	WIDTH (W)	DEPTH (D)	HEIGHT (H)	GROSS WEIGHT (LBS.)	UNCASED LIST PRICE
BVC24 24 *	14	18	10	16	US\$82
BVC24 30 *	14	18	12	17	US\$94
BVC24 36	16-3/4	18	14	21	US\$109
BVC24 42	19-1/4	18	16	23	US\$127
BVR24 48-Z16	19-1/4	19	18	25	US\$135
BV132 60-Z19	22-3/4	19	22	37	US\$208

* Available in a fully-stamped drain pan.