

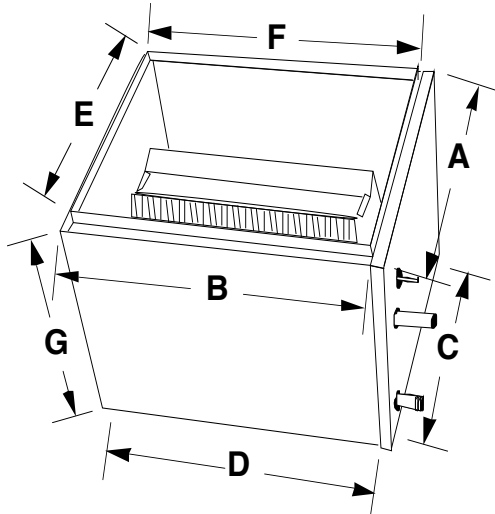

DIMENSIONS AND SPECIFICATIONS

Aspen Cased Upflow Coils

Designed to Fit Carrier Upflow Furnaces



GENERAL SPECIFICATIONS

- Standard refrigerant connections: liquid line - 3/8" ODS, suction line - 7/8" ODS
- Left-hand refrigerant and plumbing connections.
- One 3/4" MPT condensate drain.
- Powder-painted metal drain pan. Stainless available.
- Five-year warranty.
- Flowrater standard. Factory or field-installable TXV available.
- Front access panel for easy service.
- Every coil immersion-tested at 500 psi, then nitrogen-pressurized and sealed.
- Heavy gauge embossed galvanized cabinets fully lined with 1/2" faced insulation.
- Flush-fits furnace in most applications.
- Rifled copper tubing, enhanced aluminum fins.
- ARI certifiable with all brands of A/C and heat pump systems.
- ETL listed.

CARRIER FURNACE WIDTH	ASPEN COIL MODEL	SUFFIX	FOOTPRINT		BOTTOM OPENING		TOP OPENING		HEIGHT
			A	B	C	D	E	F	
14-3/16	BV1** 24	ACT18	14-3/16	21	12-3/4	19-1/4	12-11/16	19-1/2	18
	BVR** 24	ACT12	14-3/16	21	12-3/4	19-1/4	12-11/16	19-1/2	12
	BVR** 30	ACT18	14-3/16	21	12-3/4	19-1/4	12-11/16	19-1/2	18
	BV1** 30	ACT18	14-3/16	21	12-3/4	19-1/4	12-11/16	19-1/2	18
	BVR** 36	ACT18	14-3/16	21	12-3/4	19-1/4	12-11/16	19-1/2	18
	BV5** 36	ACT18	14-3/16	21	12-3/4	19-1/4	12-11/16	19-1/2	18
17-1/2	BVR** 24	ACV16	17-1/2	21	16-1/8	19-1/4	16	19-1/2	16
	BV1** 24	ACV16	17-1/2	21	16-1/8	19-1/4	16	19-1/2	16
	BVR** 30	ACV16	17-1/2	21	16-1/8	19-1/4	16	19-1/2	16
	BV1** 30	ACV16	17-1/2	21	16-1/8	19-1/4	16	19-1/2	16
	BVR** 36	ACV16	17-1/2	21	16-1/8	19-1/4	16	19-1/2	16
	BV5** 36	ACV22	17-1/2	21	16-1/8	19-1/4	16	19-1/2	22
	BVR** 42	ACV22	17-1/2	21	16-1/8	19-1/4	16	19-1/2	22
	BV5** 42	ACV22	17-1/2	21	16-1/8	19-1/4	16	19-1/2	22
	BVR** 48	ACV22	17-1/2	21	16-1/8	19-1/4	16	19-1/2	22
	BV1** 48	ACV22	17-1/2	21	16-1/8	19-1/4	16	19-1/2	22
21	BVR** 36	ACW16	21	21	19-5/8	19-1/4	19-1/2	19-1/2	16
	BV5** 36	ACW22	21	21	19-5/8	19-1/4	19-1/2	19-1/2	22
	BVR** 42	ACW22	21	21	19-5/8	19-1/4	19-1/2	19-1/2	22
	BV5** 42	ACW22	21	21	19-5/8	19-1/4	19-1/2	19-1/2	22
	BVR** 48	ACW22	21	21	19-5/8	19-1/4	19-1/2	19-1/2	22
	BV1** 48	ACW22	21	21	19-5/8	19-1/4	19-1/2	19-1/2	22
24-1/2	BVR** 48	ACX24	24-1/2	21	23-1/8	19-1/4	23	19-1/2	24
	BV1** 48	ACX24	24-1/2	21	23-1/8	19-1/4	23	19-1/2	24
	BV5** 48	ACX24	24-1/2	21	23-1/8	19-1/4	23	19-1/2	24
	BV1** 60	ACX24	24-1/2	21	23-1/8	19-1/4	23	19-1/2	24
	BV2** 60	ACY26	24-1/2	23	23-1/8	19-1/4	23	21-1/2	26
	BV7** 60	ACX26	24-1/2	21	23-1/8	19-1/4	23	19-1/2	26