

## DIMENSIONS AND SPECIFICATIONS

### Aspen Cased Upflow Coils

Designed for Coleman AGU, BGU Series Furnaces

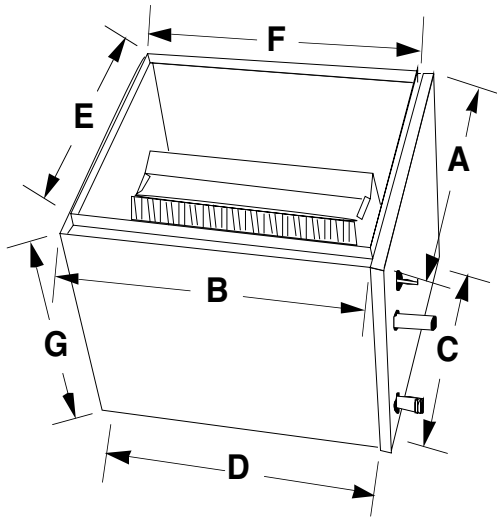

#### GENERAL SPECIFICATIONS

- Standard refrigerant connections: liquid line - 3/8" ODS, suction line - 7/8" ODS
- Left-hand refrigerant and plumbing connections.
- One 3/4" MPT condensate drain.
- Powder-painted metal drain pan. Stainless available.
- Five-year warranty.
- Flowrater standard. Factory or field-installable TXV available.
- Front access panel for easy service.
- Every coil immersion-tested at 500 psi, then nitrogen-pressurized and sealed.
- Heavy gauge embossed galvanized cabinets fully lined with 1/2" faced insulation.
- Flush-fits furnace in most applications.
- Riffled copper tubing, enhanced aluminum fins.
- ARI certifiable with all brands of A/C and heat pump systems.
- ETL listed.

COLEMAN FURNACE MODEL	ASPEN COIL MODEL	SUFFIX	FOOTPRINT		BOTTOM OPENING		TOP OPENING		HEIGHT
			A	B	C	D	E	F	
AGU05010A, 12A, 7512A	BVR** 24	A5J14	16-7/8	22-1/8	15-5/8	20-5/8	15-3/8	20-5/8	14
	BV1** 24	A5J14	16-7/8	22-1/8	15-5/8	20-5/8	15-3/8	20-5/8	14
	BVR** 30	A5J14	16-7/8	22-1/8	15-5/8	20-5/8	15-3/8	20-5/8	14
BGU05010A, 12A, 7512A	BV1** 30	A5J18	16-7/8	22-1/8	15-5/8	20-5/8	15-3/8	20-5/8	18
	BVR** 36	A5J18	16-7/8	22-1/8	15-5/8	20-5/8	15-3/8	20-5/8	18
	BV5** 36	A5J18	16-7/8	22-1/8	15-5/8	20-5/8	15-3/8	20-5/8	18
AGU07516A, 10016A	BVR** 30	A5K14	20	22-1/8	18-3/4	20-5/8	18-1/2	20-5/8	14
	BV1** 30	A5K18	20	22-1/8	18-3/4	20-5/8	18-1/2	20-5/8	18
	BVR** 36	A5K18	20	22-1/8	18-3/4	20-5/8	18-1/2	20-5/8	18
	BV5** 36	A5K18	20	22-1/8	18-3/4	20-5/8	18-1/2	20-5/8	18
BGU07516A, 10016A	BVR** 42	A5K18	20	22-1/8	18-3/4	20-5/8	18-1/2	20-5/8	18
	BV5** 42	A5K22	20	22-1/8	18-3/4	20-5/8	18-1/2	20-5/8	22
	BVR** 48	A5K22	20	22-1/8	18-3/4	20-5/8	18-1/2	20-5/8	22
	BV1** 48	A5K26	20	22-1/8	18-3/4	20-5/8	18-1/2	20-5/8	26
AGU10020A, 12520A, 15020A	BV5** 48	A5K22	20	22-1/8	18-3/4	20-5/8	18-1/2	20-5/8	22
	BVR** 36	A5L18	23	22-1/8	21-3/4	20-5/8	21-1/2	20-5/8	18
	BV5** 36	A5L18	23	22-1/8	21-3/4	20-5/8	21-1/2	20-5/8	18
	BVR** 42	A5L18	23	22-1/8	21-3/4	20-5/8	21-1/2	20-5/8	18
	BV5** 42	A5L22	23	22-1/8	21-3/4	20-5/8	21-1/2	20-5/8	22
	BVR** 48	A5L22	23	22-1/8	21-3/4	20-5/8	21-1/2	20-5/8	22
	BV1** 48	A5L26	23	22-1/8	21-3/4	20-5/8	21-1/2	20-5/8	26
BGU10020A, 12520A, 15020A	BV5** 48	A5L22	23	22-1/8	21-3/4	20-5/8	21-1/2	20-5/8	22
	BV1** 60	A5L26	23	22-1/8	21-3/4	20-5/8	21-1/2	20-5/8	26
	BV7** 60	A5L26	23	22-1/8	21-3/4	20-5/8	21-1/2	20-5/8	26

Note: No bottom front break

BV Spec-Coleman A AGU. Effective 7/1/98. Supercedes all previous versions. Subject to change without notice.