

DIMENSIONS AND SPECIFICATIONS

Aspen Cased Upflow Coils

Designed for Ducane DHZA and UHZA Oil Furnaces

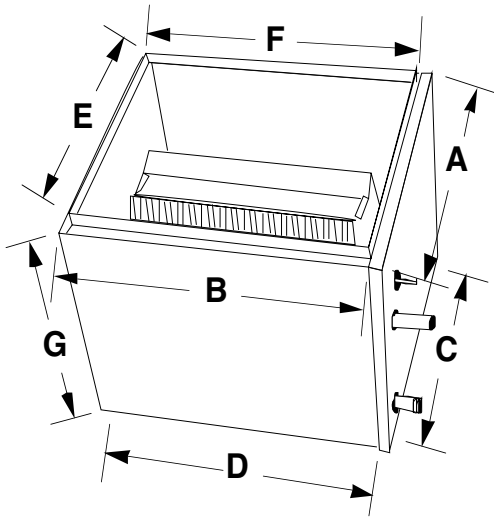

GENERAL SPECIFICATIONS

- Standard refrigerant connections: liquid line - 3/8" ODS, suction line - 7/8" ODS
- Left-hand refrigerant and plumbing connections.
- One 3/4" MPT condensate drain.
- Powder-painted metal drain pan. Stainless available.
- Five-year warranty.
- Flowrater standard. Factory or field-installable TXV available.
- Front access panel for easy service.
- Every coil immersion-tested at 500 psi, then nitrogen-pressurized and sealed.
- Heavy gauge embossed galvanized cabinets fully lined with 1/2" faced insulation.
- Flush-fits furnace in most applications.
- Rifled copper tubing, enhanced aluminum fins.
- ARI certifiable with all brands of A/C and heat pump systems.
- ETL listed.

FURNACE MODEL	COIL MODEL	SUFFIX	FOOTPRINT		BOTTOM OPENING		TOP OPENING		HEIGHT
			A	B	C	D	E	F	
DHZA085A3	BVR** 24	A6G16	22	21	20-1/4	17-1/4	20-1/2	19-1/2	16
UHZA055A3	BVR** 30	A6G16	22	21	20-1/4	17-1/4	20-1/2	19-1/2	16
UHZA085A3	BVR** 36	A6G16	22	21	20-1/4	17-1/4	20-1/2	19-1/2	16
UHZA085A4									
DHZA100A4	BVR** 42	A6H24	22	23-3/4	20-1/4	22-1/4	20-1/2	22-1/4	24
DHZA125A5	BVR** 48	A6H24	22	23-3/4	20-1/4	22-1/4	20-1/2	22-1/4	24
UHZA100A4	BV1** 60	A6H24	22	23-3/4	20-1/4	22-1/4	20-1/2	22-1/4	24
UHZA100A5									
UHZA125A5									
UHZA175A5									
UHZA175A5	BV1** 60	A6J24	26	30-3/4	24-1/4	29-1/4	24-1/2	29-1/4	24