



ASPEN
MANUFACTURING

373 ATASCOCITA RD. • HUMBLE, TX • 77396
TEL (281) 441-6500 • FAX (281) 441-6510
<< www.aspenmfg.com >>

DIMENSIONS AND SPECIFICATIONS

Aspen Cased Upflow/Downflow Coils

Designed for Ducane DCFA Oil Furnaces

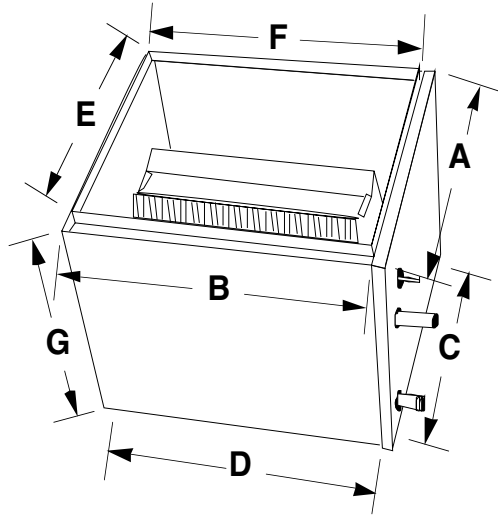

GENERAL SPECIFICATIONS

- Standard refrigerant connections: liquid line - 3/8" ODS, suction line - 7/8" ODS
- Left-hand refrigerant and plumbing connections.
- One 3/4" MPT condensate drain.
- Powder-painted metal drain pan. Stainless available.
- Five-year warranty.
- Flowrater standard. Factory or field-installable TXV available.
- Front access panel for easy service.
- Every coil immersion-tested at 500 psi, then nitrogen-pressurized and sealed.
- Heavy guage embossed galvanized cabinets fully lined with 1/2" faced insulation.
- Flush-fits furnace in most applications.
- Rifled copper tubing, enhanced aluminum fins.
- ARI certifiable with all brands of A/C and heat pump systems.
- ETL listed.

FURNACE MODEL	COIL MODEL	SUFFIX	FOOTPRINT		BOTTOM OPENING		TOP OPENING		HEIGHT
			A	B	C	D	E	F	
DCFA085A3	BVR** 36	C6H24	22	23-3/4	20-1/4	22-1/4	19-3/4	21-3/4	24
DCFA112A4	BVR** 42	C6H24	22	23-3/4	20-1/4	22-1/4	19-3/4	21-3/4	24
	BVR** 48	C6H24	22	23-3/4	20-1/4	22-1/4	19-3/4	21-3/4	24