



**ASPEN**  
MANUFACTURING

373 ATASCOCITA RD. • HUMBLE, TX • 77396  
TEL (281) 441-6500 • FAX (281) 441-6510  
<< www.aspenmfg.com >>

## DIMENSIONS AND SPECIFICATIONS

### Aspen Cased Upflow Coils

Designed for Goodman GMP Furnaces

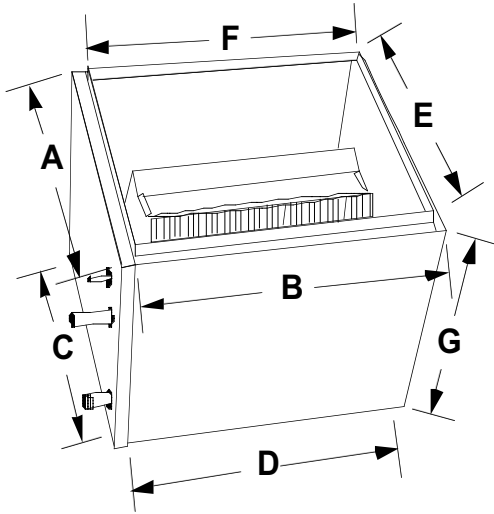

#### GENERAL SPECIFICATIONS

- Standard refrigerant connections: liquid line - 3/8" ODS, suction line - 7/8" ODS
- Right-hand refrigerant and plumbing connections.
- One 3/4" MPT condensate drain.
- Powder-painted metal drain pan. Stainless available.
- Five-year warranty.
- Flowrater standard. Factory or field-installable TXV available.
- Front access panel for easy service.
- Every coil immersion-tested at 500 psi, then nitrogen-pressurized and sealed.
- Heavy gauge embossed galvanized cabinets fully lined with 1/2" faced insulation.
- Flush-fits furnace in most applications.
- Rifled copper tubing, enhanced aluminum fins.
- ARI certifiable with all brands of A/C and heat pump systems.
- ETL listed.

FURNACE MODEL	COIL MODEL	SUFFIX	FOOTPRINT		BOTTOM OPENING		TOP OPENING		HEIGHT
			A	B	C	D	E	F	
GMP050-3, 075-3 GMPN060-3	BV1** 24	AJX18	14-1/2	22	12-3/4	20-1/2	13	19-1/2	18
	BVR** 24	AJX12	14-1/2	22	12-3/4	20-1/2	13	19-1/2	12
	BV1** 30	AJX18	14-1/2	22	12-3/4	20-1/2	13	19-1/2	18
	BVR** 30	AJX18	14-1/2	22	12-3/4	20-1/2	13	19-1/2	18
	BV5** 36	AJX18	14-1/2	22	12-3/4	20-1/2	13	19-1/2	18
	BVR** 36	AJX18	14-1/2	22	12-3/4	20-1/2	13	19-1/2	18
GMP075-4, 100-3, 100-4 GMPN080-4	BV5** 36	AJY18	17-1/2	22	16-1/4	20-1/2	16	19-1/2	18
	BVR** 36	AJY18	17-1/2	22	16-1/4	20-1/2	16	19-1/2	18
	BV5** 42	AJY24	17-1/2	22	16-1/4	20-1/2	16	19-1/2	24
	BVR** 42	AJY18	17-1/2	22	16-1/4	20-1/2	16	19-1/2	18
	BV1** 48	AJY24	17-1/2	22	16-1/4	20-1/2	16	19-1/2	24
	BV5** 48	AJY24	17-1/2	22	16-1/4	20-1/2	16	19-1/2	24
GMP100-5, 125-4, 125-5 GMPN100-4	BV1** 48	AJZ26	21	22	19-3/4	20-1/2	19-1/2	19-1/2	26
	BV5** 48	AJZ26	21	22	19-3/4	20-1/2	19-1/2	19-1/2	26
	BVR** 48	AJZ20	21	22	19-3/4	20-1/2	19-1/2	19-1/2	20
	BV1** 60	AJZ26	21	22	19-3/4	20-1/2	19-1/2	19-1/2	26
	BV2** 60	A2T26	21	23	19-3/4	20-1/2	19-1/2	21-1/2	26
	BV7** 60	AJZ26	21	22	19-3/4	20-1/2	19-1/2	19-1/2	26
GMP150-5 GMPN120-5	BV1** 48	A2S26	24-1/2	22	23-1/4	20-1/2	23	19-1/2	26
	BV5** 48	A2S26	24-1/2	22	23-1/4	20-1/2	23	19-1/2	26
	BVR** 48	A2S20	24-1/2	22	23-1/4	20-1/2	23	19-1/2	20
	BV1** 60	A2S26	24-1/2	22	23-1/4	20-1/2	23	19-1/2	26
	BV2** 60	A2U26	24-1/2	23	23-1/4	20-1/2	23	21-1/2	26
	BV7** 60	A2S26	24-1/2	22	23-1/4	20-1/2	23	19-1/2	26

BV Spec-Goodman A GMP GMPN. Effective 6/3/99. Supercedes all previous versions. Subject to change without notice.