



ASPEN
MANUFACTURING

373 ATASCOCITA RD. • HUMBLE, TX • 77396
TEL (281) 441-6500 • FAX (281) 441-6510
<< www.aspenmfg.com >>

DIMENSIONS AND SPECIFICATIONS

Aspen Cased Upflow/Downflow Coils

Designed for Goodman GMP Furnaces

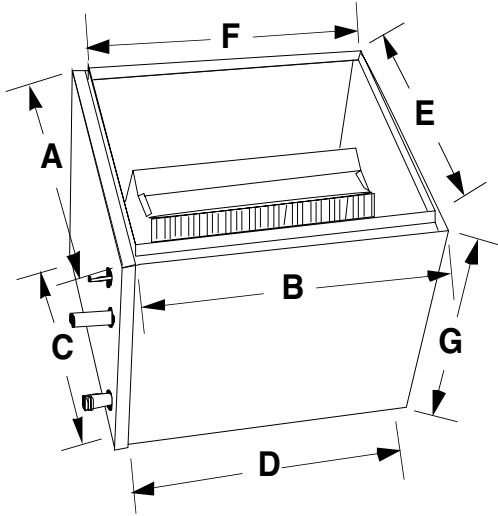

GENERAL SPECIFICATIONS

- Standard refrigerant connections: liquid line - 3/8" ODS, suction line - 7/8" ODS
- Right-hand refrigerant and plumbing connections.
- One 3/4" MPT condensate drain.
- Powder-painted metal drain pan. Stainless available.
- Five-year warranty.
- Flowrater standard. Factory or field-installable TXV available.
- Front access panel for easy service.
- Every coil immersion-tested at 500 psi, then nitrogen-pressurized and sealed.
- Heavy gauge embossed galvanized cabinets fully lined with 1/2" faced insulation.
- Flush-fits furnace in most applications.
- Rifled copper tubing, enhanced aluminum fins.
- ARI certifiable with all brands of A/C and heat pump systems.
- ETL listed.

FURNACE MODEL	COIL MODEL	SUFFIX	FOOTPRINT		BOTTOM OPENING		TOP OPENING		HEIGHT
			A	B	C	D	E	F	
GMP050-3 GMP075-3	BV1** 24	CJX18	14-1/2	22	12-3/4	20-1/2	12-1/4	15-5/8	18
	BVR** 24	CJX12	14-1/2	22	12-3/4	20-1/2	12-1/4	15-5/8	12
	BV1** 30	CJX18	14-1/2	22	12-3/4	20-1/2	12-1/4	15-5/8	18
	BVR** 30	CJX18	14-1/2	22	12-3/4	20-1/2	12-1/4	15-5/8	18
	BV5** 36	CJX18	14-1/2	22	12-3/4	20-1/2	12-1/4	15-5/8	18
	BVR** 36	CJX18	14-1/2	22	12-3/4	20-1/2	12-1/4	15-5/8	18
GMP075-4 GMP100-3 GMP100-4	BV5** 36	CJY18	17-1/2	22	16-1/4	20-1/2	15-3/4	15-5/8	18
	BVR** 36	CJY18	17-1/2	22	16-1/4	20-1/2	15-3/4	15-5/8	18
	BV5** 42	CJY24	17-1/2	22	16-1/4	20-1/2	15-3/4	15-5/8	24
	BVR** 42	CJY18	17-1/2	22	16-1/4	20-1/2	15-3/4	15-5/8	18
	BV1** 48	CJY24	17-1/2	22	16-1/4	20-1/2	15-3/4	15-5/8	24
	BV5** 48	CJY24	17-1/2	22	16-1/4	20-1/2	15-3/4	15-5/8	24
GMP100-5 GMP125-4 GMP125-5	BV5** 42	CJZ20	21	22	19-3/4	20-1/2	19-1/4	15-5/8	20
	BVR** 42	CJZ20	21	22	19-3/4	20-1/2	19-1/4	15-5/8	20
	BV1** 48	CJZ26	21	22	19-3/4	20-1/2	19-1/4	15-5/8	26
	BV5** 48	CJZ26	21	22	19-3/4	20-1/2	19-1/4	15-5/8	26
	BVR** 48	CJZ20	21	22	19-3/4	20-1/2	19-1/4	15-5/8	20
	BV1** 60	CJZ26	21	22	19-3/4	20-1/2	19-1/4	15-5/8	26
GMP150-5	BV1** 48	C2S26	24-1/2	22	23-1/4	20-1/2	22-3/4	15-5/8	26
	BV5** 48	C2S26	24-1/2	22	23-1/4	20-1/2	22-3/4	15-5/8	26
	BVR** 48	C2S20	24-1/2	22	23-1/4	20-1/2	22-3/4	15-5/8	20
	BV1** 60	C2S26	24-1/2	22	23-1/4	20-1/2	22-3/4	15-5/8	26
	BV2** 60	C2U26	24-1/2	23	23-1/4	20-1/2	22-3/4	15-5/8	26
	BV7** 60	C2S26	24-1/2	22	23-1/4	20-1/2	22-3/4	15-5/8	26

BV Spec-Goodman C. Effective 4/30/98. Supercedes all previous versions. Subject to change without notice.