

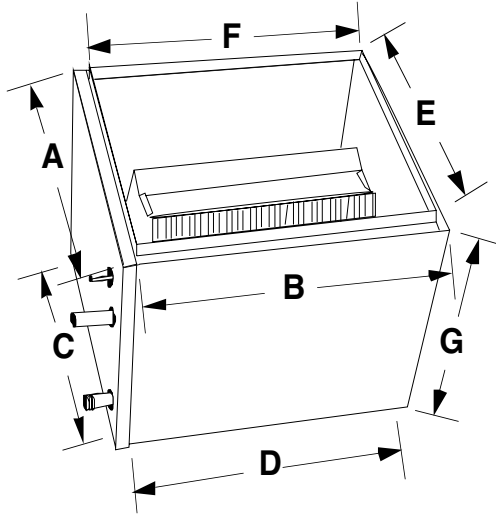

DIMENSIONS AND SPECIFICATIONS

Aspen Cased Upflow Coils

Designed for Lennox G40, G50, and G60 Upflow/Horizontal Furnaces



GENERAL SPECIFICATIONS

- Standard refrigerant connections: liquid line - 3/8" ODS, suction line - 7/8" ODS
- Right-hand refrigerant and plumbing connections.
- One 3/4" MPT condensate drain.
- Powder-painted metal drain pan. Stainless available.
- Five-year warranty.
- Flowrater standard. Factory or field-installable TXV available.
- Front access panel for easy service.
- Every coil immersion-tested at 500 psi, then nitrogen-pressurized and sealed.
- Heavy gauge embossed galvanized cabinets fully lined with 1/2" faced insulation.
- Flush-fits furnace in most applications.
- Rified copper tubing, enhanced aluminum fins.
- ARI certifiable with all brands of A/C and heat pump systems.
- ETL listed.

LENNOX FURNACE MODEL	ASPEN COIL MODEL	SUFFIX	FOOTPRINT		BOTTOM OPENING		TOP OPENING		HEIGHT
			A	B	C	D	E	F	
G40/50/60UH-24A G40/50/60UH-36A	BV1** 24	APA16	14-5/8	21-1/4	13-5/8	19-3/4	13-1/8	19-3/4	16
	BVR** 24	APA12	14-5/8	21-1/4	13-5/8	19-3/4	13-1/8	19-3/4	12
	BV1** 30	APA16	14-5/8	21-1/4	13-5/8	19-3/4	13-1/8	19-3/4	16
	BVR** 30	APA16	14-5/8	21-1/4	13-5/8	19-3/4	13-1/8	19-3/4	16
	BV1** 36	APA20	14-5/8	21-1/4	13-5/8	19-3/4	13-1/8	19-3/4	20
	BV5** 36	APA18	14-5/8	21-1/4	13-5/8	19-3/4	13-1/8	19-3/4	18
	BVR** 36	APA16	14-5/8	21-1/4	13-5/8	19-3/4	13-1/8	19-3/4	16
	BV5** 42	APA20	14-5/8	21-1/4	13-5/8	19-3/4	13-1/8	19-3/4	20
	BVR** 42	APA18	14-5/8	21-1/4	13-5/8	19-3/4	13-1/8	19-3/4	18
G40/50/60UH-36B G40/50/60UH-48B	BV1** 30	APB16	17-5/8	21-1/4	16-5/8	19-3/4	16-1/8	19-3/4	16
	BVR** 30	APB16	17-5/8	21-1/4	16-5/8	19-3/4	16-1/8	19-3/4	16
	BV1** 36	APB20	17-5/8	21-1/4	16-5/8	19-3/4	16-1/8	19-3/4	20
	BV5** 36	APB20	17-5/8	21-1/4	16-5/8	19-3/4	16-1/8	19-3/4	20
	BVR** 36	APB16	17-5/8	21-1/4	16-5/8	19-3/4	16-1/8	19-3/4	16
	BV5** 42	APB20	17-5/8	21-1/4	16-5/8	19-3/4	16-1/8	19-3/4	20
	BVR** 42	APB20	17-5/8	21-1/4	16-5/8	19-3/4	16-1/8	19-3/4	20
	BV1** 48	APB24	17-5/8	21-1/4	16-5/8	19-3/4	16-1/8	19-3/4	24
	BV5** 48	APB24	17-5/8	21-1/4	16-5/8	19-3/4	16-1/8	19-3/4	24
G40/50/60UH-36C G40/50/60UH-48C G40/50/60UH-60C	BV5** 42	APC20	21-1/8	21-1/4	20-1/8	19-3/4	19-5/8	19-3/4	20
	BVR** 42	APC20	21-1/8	21-1/4	20-1/8	19-3/4	19-5/8	19-3/4	20
	BV1** 48	APC26	21-1/8	21-1/4	20-1/8	19-3/4	19-5/8	19-3/4	26
	BV5** 48	APC26	21-1/8	21-1/4	20-1/8	19-3/4	19-5/8	19-3/4	26
	BVR** 48	APC20	21-1/8	21-1/4	20-1/8	19-3/4	19-5/8	19-3/4	20
	BV1** 60	APC26	21-1/8	21-1/4	20-1/8	19-3/4	19-5/8	19-3/4	26
	BV7** 60	APC26	21-1/8	21-1/4	20-1/8	19-3/4	19-5/8	19-3/4	26
G40/50/60UH-60D	BV2** 60	APE26	21-1/8	23	20-1/8	19-3/4	19-5/8	21-1/2	26
	BV1** 60	APD26	24-5/8	21-1/4	23-5/8	19-3/4	23-1/8	19-3/4	26
	BV7** 60	APD26	24-5/8	21-1/4	23-5/8	19-3/4	23-1/8	19-3/4	26
									26

BV Spec-Lennox A G40/50/60UH. Effective 1/17/03. Supercedes all previous versions. Subject to change without notice.