

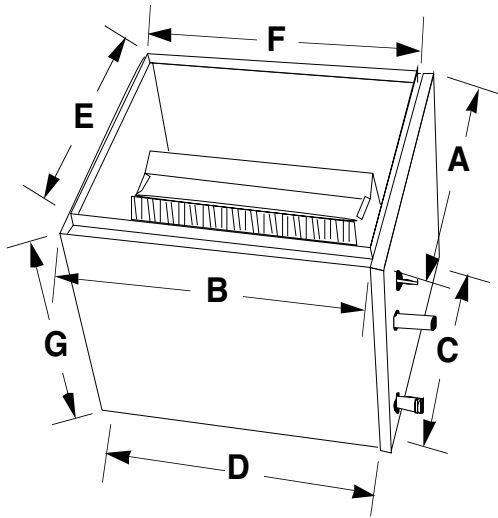

DIMENSIONS AND SPECIFICATIONS

Aspen Cased Upflow Coils

Designed for Luxaire PABU Series Furnaces



GENERAL SPECIFICATIONS

- Standard refrigerant connections: liquid line - 3/8" ODS, suction line - 7/8" ODS
- Left-hand refrigerant and plumbing connections.
- One 3/4" MPT condensate drain.
- Powder-painted metal drain pan. Stainless available.
- Five-year warranty.
- Flowrater standard. Factory or field-installable TXV available.
- Front access panel for easy service.
- Every coil immersion-tested at 500 psi, then nitrogen-pressurized and sealed.
- Heavy gauge embossed galvanized cabinets fully lined with 1/2" faced insulation.
- Flush-fits furnace in most applications.
- Rifled copper tubing, enhanced aluminum fins.
- ARI certifiable with all brands of A/C and heat pump systems.
- ETL listed.

LUXAIRE FURNACE MODEL	ASPEN COIL MODEL	SUFFIX	FOOTPRINT		BOTTOM OPENING		TOP OPENING		HEIGHT
			A	B	C	D	E	F	
PABU-LD10N050	BV1** 24	A5J14	16-7/8	22-1/8	15-5/8	20-5/8	15-3/8	20-5/8	14
PABU-LD12N050	BVR** 24	A5J14	16-7/8	22-1/8	15-5/8	20-5/8	15-3/8	20-5/8	14
PABU-LD12N075	BV1** 30	A5J20	16-7/8	22-1/8	15-5/8	20-5/8	15-3/8	20-5/8	20
	BV1** 36	A5J20	16-7/8	22-1/8	15-5/8	20-5/8	15-3/8	20-5/8	20
PABU-LD16N075 PABU-LD16N100	BV1** 30	A5K20	20	22-1/8	18-3/4	20-5/8	18-1/2	20-5/8	20
	BV1** 36	A5K20	20	22-1/8	18-3/4	20-5/8	18-1/2	20-5/8	20
	BV1** 48	A5K24	20	22-1/8	18-3/4	20-5/8	18-1/2	20-5/8	24
PABU-LD20N100 PABU-LD20N125 PABU-LD20N150	BV1** 36	A5L20	23	22-1/8	21-3/4	20-5/8	21-1/2	20-5/8	20
	BV1** 48	A5L26	23	22-1/8	21-3/4	20-5/8	21-1/2	20-5/8	26
	BV7** 60	A5L26	23	22-1/8	21-3/4	20-5/8	21-1/2	20-5/8	26

Note: No bottom front break