

## DIMENSIONS AND SPECIFICATIONS

### Aspen Cased Upflow Coils

Designed for Luxaire PAUP/DP Upflow/Downflow Furnaces

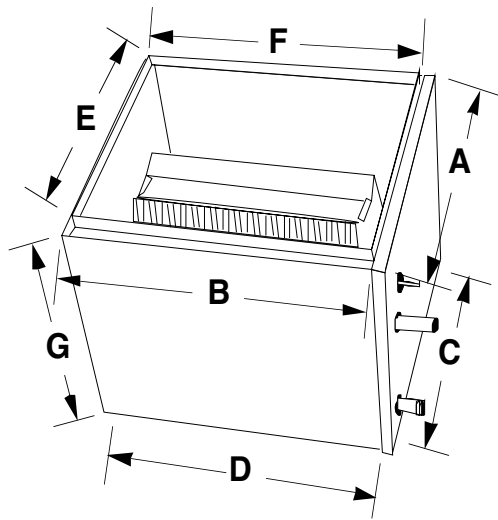

#### GENERAL SPECIFICATIONS

- Standard refrigerant connections: liquid line - 3/8" ODS, suction line - 7/8" ODS
- Left-hand refrigerant and plumbing connections.
- One 3/4" MPT condensate drain.
- Powder-painted metal drain pan. Stainless available.
- Five-year warranty.
- Flowrater standard. Factory or field-installable TXV available.
- Front access panel for easy service.
- Every coil immersion-tested at 500 psi, then nitrogen-pressurized and sealed.
- Heavy gauge embossed galvanized cabinets fully lined with 1/2" faced insulation.
- Flush-fits furnace in most applications.
- Rifled copper tubing, enhanced aluminum fins.
- ARI certifiable with all brands of A/C and heat pump systems.
- ETL listed.

FURNACE MODEL	COIL MODEL	SUFFIX	FOOTPRINT		BOTTOM OPENING		TOP OPENING		HEIGHT
			A	B	C	D	E	F	G
PAUP/DP-LD12N050	BVR** 24	AYK14	17-1/2	21-3/4	16-1/2	20-1/4	16	20-1/4	14
PAUP/DP-LD12N075	BVR** 30	AYK14	17-1/2	21-3/4	16-1/2	20-1/4	16	20-1/4	14
	BV1** 36	AYK20	17-1/2	21-3/4	16-1/2	20-1/4	16	20-1/4	20
PAUP/DP-LD16N075	BV1** 36	AYL20	21	21-3/4	20	20-1/4	19-1/2	20-1/4	20
PAUP/DP-LD16N100	BVR** 48	AYL20	21	21-3/4	20	20-1/4	19-1/2	20-1/4	20
PAUP/DP-LD20N100	BVR** 48	AYM24	24-1/2	21-3/4	23-1/2	20-1/4	23	20-1/4	24
PAUP/DP-LD20N125	BV1** 60	AYM24	24-1/2	21-3/4	23-1/2	20-1/4	23	20-1/4	24