

## DIMENSIONS AND SPECIFICATIONS

### Aspen Cased Upflow Coils

Designed for Luxaire PBKM Furnaces

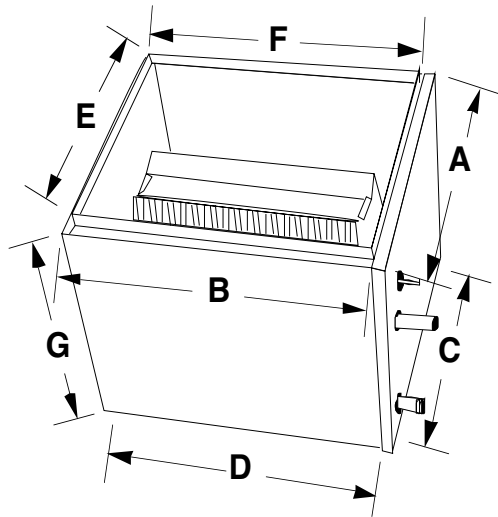

#### GENERAL SPECIFICATIONS

- Standard refrigerant connections: liquid line - 3/8" ODS, suction line - 7/8" ODS
- Left-hand refrigerant and plumbing connections.
- One 3/4" MPT condensate drain.
- Powder-painted metal drain pan. Stainless available.
- Five-year warranty.
- Flowrater standard. Factory or field-installable TXV available.
- Front access panel for easy service.
- Every coil immersion-tested at 500 psi, then nitrogen-pressurized and sealed.
- Heavy gauge embossed galvanized cabinets fully lined with 1/2" faced insulation.
- Flush-fits furnace in most applications.
- Rifled copper tubing, enhanced aluminum fins.
- ARI certifiable with all brands of A/C and heat pump systems.
- ETL listed.

FURNACE MODEL	COIL MODEL	SUFFIX	FOOTPRINT		BOTTOM OPENING		TOP OPENING		HEIGHT
			A	B	C	D	E	F	
PBKM-LD08N040	BV1** 24	AY814	14-1/2	21-3/4	11-1/4	20-1/4	13	20-1/4	14
PBKM-LD08N060	BV1** 24	AY914	16-1/4	21-3/4	15-1/4	20-1/4	14-3/4	20-1/4	14
PBKM-LD16N060	BV1** 30	AY918	16-1/4	21-3/4	15-1/4	20-1/4	14-3/4	20-1/4	18
PBKM-LD12N080	BV5** 36	AY918	16-1/4	21-3/4	15-1/4	20-1/4	14-3/4	20-1/4	18
PBKM-LD16N080	BV5** 42	AYC22	22-1/4	21-3/4	21-1/4	20-1/4	20-3/4	20-1/4	22
PBKM-LD14N100	BV1** 48	AYC26	22-1/4	21-3/4	21-1/4	20-1/4	20-3/4	20-1/4	26
PBKM-LD20N100	BV5** 48	AYC22	22-1/4	21-3/4	21-1/4	20-1/4	20-3/4	20-1/4	22
PBKM-LD16N120	BV1** 60	AYC26	22-1/4	21-3/4	21-1/4	20-1/4	20-3/4	20-1/4	26
PBKM-LD20N120	BV7** 60	AYC26	22-1/4	21-3/4	21-1/4	20-1/4	20-3/4	20-1/4	26
PBKM-LD20N140	BV1** 60	AYD26	26-1/4	21-3/4	25-1/4	20-1/4	24-3/4	20-1/4	26
	BV7** 60	AYD26	26-1/4	21-3/4	25-1/4	20-1/4	24-3/4	20-1/4	26
	BV2** 60	AYE26	26-1/4	23	25-1/4	20-1/4	24-3/4	21-1/2	26