

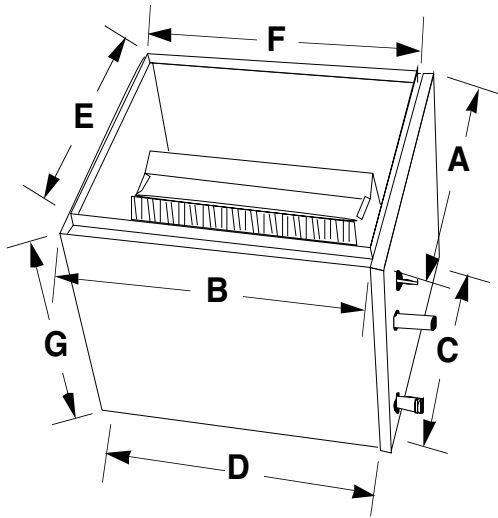

## DIMENSIONS AND SPECIFICATIONS

### Aspen Cased Upflow Coils

Designed for York P2UR Series Furnaces



**GENERAL SPECIFICATIONS**

- Standard refrigerant connections: liquid line - 3/8" ODS, suction line - 7/8" ODS
- Left-hand refrigerant and plumbing connections.
- One 3/4" MPT condensate drain.
- Powder-painted metal drain pan. Stainless available.
- Five-year warranty.
- Flowrater standard. Factory or field-installable TXV available.
- Front access panel for easy service.
- Every coil immersion-tested at 500 psi, then nitrogen-pressurized and sealed.
- Heavy gauge embossed galvanized cabinets fully lined with 1/2" faced insulation.
- Flush-fits furnace in most applications.
- Rifled copper tubing, enhanced aluminum fins.
- ARI certifiable with all brands of A/C and heat pump systems.
- ETL listed.

YORK FURNACE MODEL	ASPEN COIL MODEL	SUFFIX	FOOTPRINT		BOTTOM OPENING		TOP OPENING		HEIGHT
			A	B	C	D	E	F	
P2URD08N03701	BVR** 24	A5P12	14-1/2	21-3/4	13	20-1/4	13	20-1/4	12
P2URD10N05501	BVR** 24	A5Q14	17-1/2	21-3/4	16-1/2	20-1/4	16	20-1/4	14
P2URD12N07501	BVR** 30	A5Q14	17-1/2	21-3/4	16-1/2	20-1/4	16	20-1/4	14
	BV1** 36	A5Q20	17-1/2	21-3/4	16-1/2	20-1/4	16	20-1/4	20
P2URD16N07501	BV1** 36	A5R24	21	21-3/4	20	20-1/4	19-1/2	20-1/4	24
P2URD14N09501	BVR** 48	A5R24	21	21-3/4	20	20-1/4	19-1/2	20-1/4	24
P2URD20N09501	BV1** 60	A5R24	21	21-3/4	20	20-1/4	19-1/2	20-1/4	24
P2URD20N11201	BVR** 48	A5S24	24-1/2	21-3/4	23-1/2	20-1/4	23	20-1/4	24
P2URD20N13001	BV1** 60	A5S24	24-1/2	21-3/4	23-1/2	20-1/4	23	20-1/4	24