

DIMENSIONS AND SPECIFICATIONS

Aspen Cased Upflow Coils

Designed for York P3HU Upflow/Horizontal Furnaces

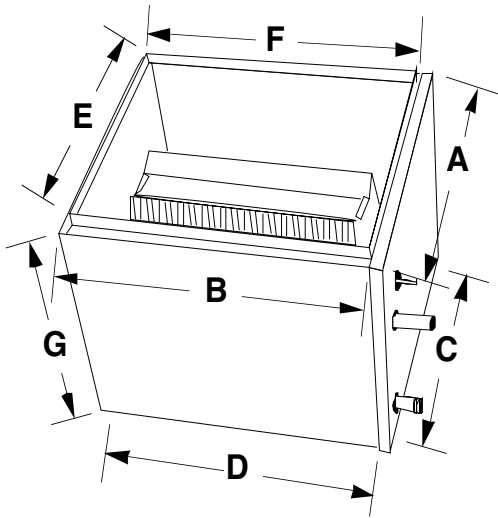

GENERAL SPECIFICATIONS

- Standard refrigerant connections: liquid line - 3/8" ODS, suction line - 7/8" ODS
- Left-hand refrigerant and plumbing connections.
- One 3/4" MPT condensate drain.
- Powder-painted metal drain pan. Stainless available.
- Five-year warranty.
- Flowrate standard. Factory or field-installable TXV available.
- Front access panel for easy service.
- Every coil immersion-tested at 500 psi, then nitrogen-pressurized and sealed.
- Heavy gauge embossed galvanized cabinets fully lined with 1/2" faced insulation.
- Flush-fits furnace in most applications.
- Rifled copper tubing, enhanced aluminum fins.
- ARI certifiable with all brands of A/C and heat pump systems.
- ETL listed.

FURNACE MODEL	COIL MODEL	SUFFIX	FOOTPRINT		BOTTOM OPENING		TOP OPENING		HEIGHT
			A	B	C	D	E	F	
P3HUA*	BVR** 24	AYR12	14-1/2	21-3/4	13-1/2	20-1/4	13	20-1/4	12
	BV1** 24	AYR18	14-1/2	21-3/4	13-1/2	20-1/4	13	20-1/4	18
	BV1** 30	AYR18	14-1/2	21-3/4	13-1/2	20-1/4	13	20-1/4	18
	BVR** 30	AYR18	14-1/2	21-3/4	13-1/2	20-1/4	13	20-1/4	18
	BV5** 36	AYR18	14-1/2	21-3/4	13-1/2	20-1/4	13	20-1/4	18
	BVR** 36	AYR18	14-1/2	21-3/4	13-1/2	20-1/4	13	20-1/4	18
P3HUB*	BV1** 24	AYK14	17-1/2	21-3/4	16-1/2	20-1/4	16	20-1/4	14
	BV1** 30	AYK20	17-1/2	21-3/4	16-1/2	20-1/4	16	20-1/4	20
	BVR** 30	AYK14	17-1/2	21-3/4	16-1/2	20-1/4	16	20-1/4	14
	BVR** 36	AYK20	17-1/2	21-3/4	16-1/2	20-1/4	16	20-1/4	20
	BVR** 42	AYK20	17-1/2	21-3/4	16-1/2	20-1/4	16	20-1/4	20
	BVR** 48	AYK20	17-1/2	21-3/4	16-1/2	20-1/4	16	20-1/4	20
P3HUC*	BV1** 24	AYL18	21	21-3/4	20	20-1/4	19-1/2	20-1/4	18
	BVR** 30	AYL18	21	21-3/4	20	20-1/4	19-1/2	20-1/4	18
	BV1** 30	AYL18	21	21-3/4	20	20-1/4	19-1/2	20-1/4	18
	BVR** 36	AYL18	21	21-3/4	20	20-1/4	19-1/2	20-1/4	18
	BVR** 42	AYL18	21	21-3/4	20	20-1/4	19-1/2	20-1/4	18
	BVR** 48	AYL24	21	21-3/4	20	20-1/4	19-1/2	20-1/4	24
	BV1** 60	AYL24	21	21-3/4	20	20-1/4	19-1/2	20-1/4	24
	BV2** 60	AYV26	21	23	20	20-1/4	19-1/2	21-1/2	26
P3HUD*	BVR** 42	AYM24	24-1/2	21-3/4	23-1/2	20-1/4	23	20-1/4	24
	BVR** 48	AYM24	24-1/2	21-3/4	23-1/2	20-1/4	23	20-1/4	24
	BV1** 60	AYM24	24-1/2	21-3/4	23-1/2	20-1/4	23	20-1/4	24
	BV2** 60	AYW26	24-1/2	23	23-1/2	20-1/4	23	21-1/2	26