

## DIMENSIONS AND SPECIFICATIONS

### Aspen Cased Upflow/Downflow Coils

Designed for York P1CK Upflow/Horizontal and P1CX Downflow Furnaces

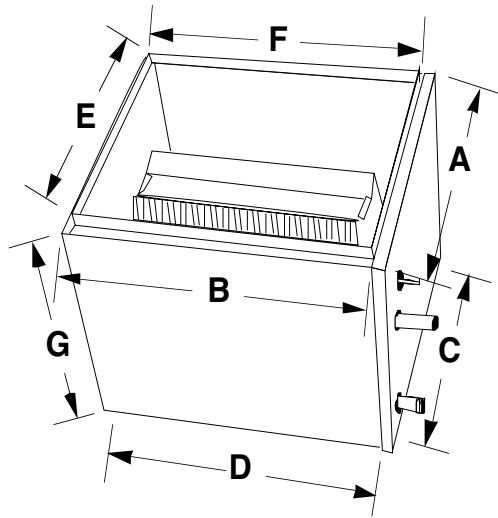

#### GENERAL SPECIFICATIONS

- Standard refrigerant connections: liquid line - 3/8" ODS, suction line - 7/8" ODS
- Left-hand refrigerant and plumbing connections.
- One 3/4" MPT condensate drain.
- Powder-painted metal drain pan. Stainless available.
- Five-year warranty.
- Flowrater standard. Factory or field-installable TXV available.
- Front access panel for easy service.
- Every coil immersion-tested at 500 psi, then nitrogen-pressurized and sealed.
- Heavy gauge embossed galvanized cabinets fully lined with 1/2" faced insulation.
- Flush-fits furnace in most applications.
- Rifled copper tubing, enhanced aluminum fins.
- ARI certifiable with all brands of A/C and heat pump systems.
- ETL listed.

FURNACE MODEL	COIL MODEL	SUFFIX	FOOTPRINT		BOTTOM OPENING		TOP OPENING		HEIGHT
			A	B	C	D	E	F	
P1CKD08*03201	BVR** 24	CY812	14-1/2	21-3/4	11-1/4	20-1/4	10-3/4	19-3/4	12
P1CKD08*04801, 12*04801, 12*06401	BVR** 24	CY916	16-1/4	21-3/4	15-1/4	20-1/4	13-3/4	19-3/4	16
	BV1** 30	CY916	16-1/4	21-3/4	15-1/4	20-1/4	13-3/4	19-3/4	16
P1CXD10N03801, 10N04801, 12N06401	BVR** 30	CY916	16-1/4	21-3/4	15-1/4	20-1/4	13-3/4	19-3/4	16
	BVR** 36	CY916	16-1/4	21-3/4	15-1/4	20-1/4	13-3/4	19-3/4	16
P1CKD16*06401, 14*08001, 20*08001, 16*09601, 20*09601	BV5** 42	CYC20	22-1/4	21-3/4	21-1/4	20-1/4	19-3/4	19-3/4	20
	BVR** 42	CYC20	22-1/4	21-3/4	21-1/4	20-1/4	19-3/4	19-3/4	20
	BV1** 48	CYC26	22-1/4	21-3/4	21-1/4	20-1/4	19-3/4	19-3/4	26
	BVR** 48	CYC20	22-1/4	21-3/4	21-1/4	20-1/4	19-3/4	19-3/4	20
P1CXD12*08001, 16*08001, 16*09201,	BV1** 60	CYC26	22-1/4	21-3/4	21-1/4	20-1/4	19-3/4	19-3/4	26
	BV7** 60	CYC26	22-1/4	21-3/4	21-1/4	20-1/4	19-3/4	19-3/4	26
P1CKD20*11201	BV1** 60	CYD26	26-1/4	21-3/4	25-1/4	20-1/4	23-3/4	19-3/4	26
P1CXD20*10401	BV7** 60	CYD26	26-1/4	21-3/4	25-1/4	20-1/4	23-3/4	19-3/4	26