

DIMENSIONS AND SPECIFICATIONS

Aspen Cased Upflow/Downflow Coils

Designed for York or Evcon/Coleman P2UH or P2CH Furnaces

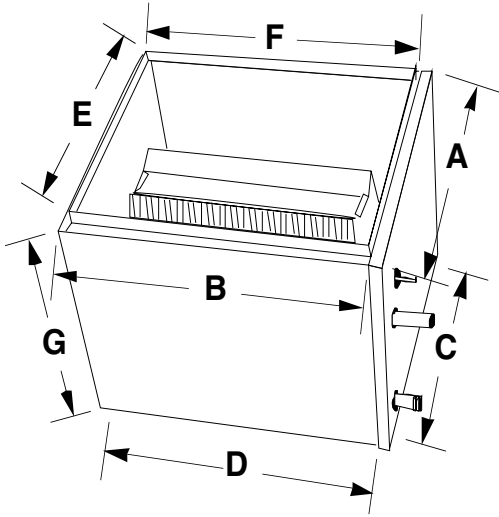

GENERAL SPECIFICATIONS

- Standard refrigerant connections: liquid line - 3/8" ODS, suction line - 7/8" ODS
- Left-hand refrigerant and plumbing connections.
- One 3/4" MPT condensate drain.
- Powder-painted galvanized steel drain pan. Stainless available.
- Five-year warranty.
- Flowrater standard. Factory or field-installable TXV available.
- Front access panel for easy service.
- Every coil immersion-tested at 500 psi, then nitrogen-pressurized and sealed.
- Heavy gauge embossed galvanized cabinets fully lined with 1/2" faced insulation.
- Flush-fits furnace in most applications.
- Rifled copper tubing, enhanced aluminum fins.
- ARI certifiable with all brands of A/C and heat pump systems.
- ETL listed.

FURNACE MODEL	COIL MODEL	SUFFIX	FOOTPRINT		BOTTOM OPENING		TOP OPENING		HEIGHT
			A	B	C	D	E	F	
P2U(C)HB12*04001 P2U(C)HB12*06001	BVR** 24	CYN14	17-1/2	21-3/4	16-1/4	20-1/4	14-1/2	18-3/8	14
	BVR** 30	CYN14	17-1/2	21-3/4	16-1/4	20-1/4	14-1/2	18-3/8	14
	BVR** 36	CYN18	17-1/2	21-3/4	16-1/4	20-1/4	14-1/2	18-3/8	18
	BVR** 42	CYN18	17-1/2	21-3/4	16-1/4	20-1/4	14-1/2	18-3/8	18
P2U(C)HC16*06001 P2U(C)HC16*08001	BVR** 36	CYP20	21	21-3/4	19-3/4	20-1/4	18	18-3/8	20
	BVR** 42	CYP20	21	21-3/4	19-3/4	20-1/4	18	18-3/8	20
	BVR** 48	CYP20	21	21-3/4	19-3/4	20-1/4	18	18-3/8	20
	BV7** 60	CYP26	21	21-3/4	19-3/4	20-1/4	18	18-3/8	26
P2U(C)HD20*08001 P2U(C)HD20*10001	BVR** 48	CYQ26	24-1/2	21-3/4	23-1/4	20-1/4	21-1/2	18-3/8	26
	BV7** 60	CYQ26	24-1/2	21-3/4	23-1/4	20-1/4	21-1/2	18-3/8	26