

DIMENSIONS AND SPECIFICATIONS

Aspen Cased Upflow/Downflow Coils

Designed for York P3HU Upflow/Horizontal and P3DN Downflow Furnaces

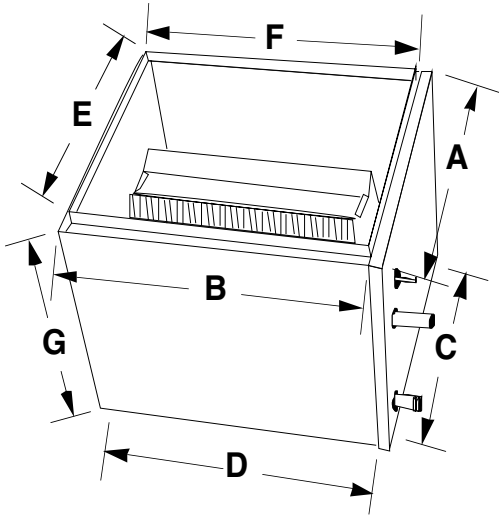

GENERAL SPECIFICATIONS

- Standard refrigerant connections: liquid line - 3/8" ODS, suction line - 7/8" ODS
- Left-hand refrigerant and plumbing connections.
- One 3/4" MPT condensate drain.
- Powder-painted metal drain pan. Stainless available.
- Five-year warranty.
- Flowrater standard. Factory or field-installable TXV available.
- Front access panel for easy service.
- Every coil immersion-tested at 500 psi, then nitrogen-pressurized and sealed.
- Heavy gauge embossed galvanized cabinets fully lined with 1/2" faced insulation.
- Flush-fits furnace in most applications.
- Rifled copper tubing, enhanced aluminum fins.
- ARI certifiable with all brands of A/C and heat pump systems.
- ETL listed.

FURNACE MODEL	COIL MODEL	SUFFIX	FOOTPRINT		BOTTOM OPENING		TOP OPENING		HEIGHT
			A	B	C	D	E	F	
P3HU(DN)A*	BVR** 24	CYR16	14-1/2	21-3/4	13-1/2	20-1/4	12	19-3/4	16
	BV1** 30	CYR16	14-1/2	21-3/4	13-1/2	20-1/4	12	19-3/4	16
	BVR** 30	CYR16	14-1/2	21-3/4	13-1/2	20-1/4	12	19-3/4	16
	BVR** 36	CYR16	14-1/2	21-3/4	13-1/2	20-1/4	12	19-3/4	16
P3HU(DN)B*	BV5** 42	CYK20	17-1/2	21-3/4	16-1/2	20-1/4	15	19-3/4	20
	BVR** 42	CYK20	17-1/2	21-3/4	16-1/2	20-1/4	15	19-3/4	20
	BV1** 48	CYK24	17-1/2	21-3/4	16-1/2	20-1/4	15	19-3/4	24
	BVR** 48	CYK20	17-1/2	21-3/4	16-1/2	20-1/4	15	19-3/4	20
P3HU(DN)C*	BV1** 60	CYL26	21	21-3/4	20	20-1/4	18-1/2	19-3/4	26
	BV7** 60	CYL26	21	21-3/4	20	20-1/4	18-1/2	19-3/4	26
P3HU(DN)D*	BV1** 60	CYM26	24-1/2	21-3/4	23-1/2	20-1/4	22	19-3/4	26
	BV7** 60	CYM26	24-1/2	21-3/4	23-1/2	20-1/4	22	19-3/4	26