

## DIMENSIONS AND SPECIFICATIONS

### Aspen Light Commercial Slab Horizontal Coils Single or Split Circuit

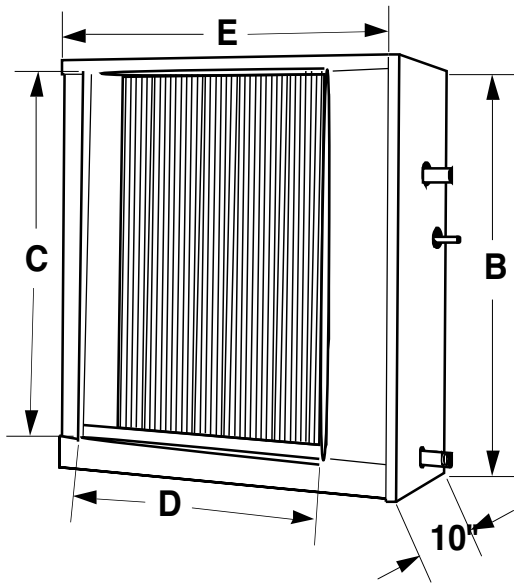

#### GENERAL SPECIFICATIONS

- Standard refrigerant connections: liquid line - 3/8" ODS, suction line - 7/8" ODS
- Left-hand refrigerant and plumbing connections.
- One 3/4" MPT condensate drain.
- Powder-painted metal drain pan. Stainless available.
- Five-year warranty.
- Factory installed 20% bleed port TXV(s) standard.
- Single circuit. Dual circuitry available.
- Dual circuit coils can be split top-to-bottom or interfaced.
- Front access panel for easy service.
- Every coil immersion-tested at 450 psi, then nitrogen-pressurized and sealed.
- Heavy guage embossed galvanized cabinets fully lined with 1/2" faced insulation.
- Flush-fits furnace in most applications.
- Rifled copper tubing, enhanced aluminum fins.
- ETL listed.

ASPEN MODEL NUMBER	HEIGHT	OPENING		LENGTH	SINGLE CIRCUIT +TXV LIST PRICE
	B	C	D	E	
BHA40 48+X1	23-1/2	21	29	34-1/2	\$242
BHA40 60+X1	25	21	29	34-1/2	\$248
BH132 72+X1	25-1/2	21	36	41-1/2	\$434
BH332 72+X1	25-1/2	21	42	47-1/2	\$470
BH132 90+X1	25-1/2	21	42	47-1/2	\$471
BH332 90+X1	25-1/2	21	45	50-1/2	\$489
BH132 120+X1	25-1/2	21	42	47-1/2	\$472
BH332 120+X1	25-1/2	21	45	50-1/2	\$490

ASPEN MODEL NUMBER	HEIGHT	OPENING		LENGTH	SPLIT CIRCUIT +TXV LIST PRICE
	B	C	D	E	
BHA40 48+X1 SPL	23-1/2	21	29	34-1/2	\$294
BHA40 60+X1 SPL	25	21	29	34-1/2	\$300
BH140 72 +X1 SPL	25-1/2	21	36	41-1/2	\$557
BH340 72 +X1 SPL	25-1/2	21	42	47-1/2	\$601
BH140 90 +X1 SPL	25-1/2	21	42	47-1/2	\$602
BH340 90 +X1 SPL	25-1/2	21	45	50-1/2	\$623
BH140 120 +X1 SPL	25-1/2	21	42	47-1/2	\$603
BH340 120 +X1 SPL	25-1/2	21	45	50-1/2	\$624