

## DIMENSIONS AND SPECIFICATIONS

### Aspen Horizontal Coils

Designed to Replace Goodman® Horizontal Coils

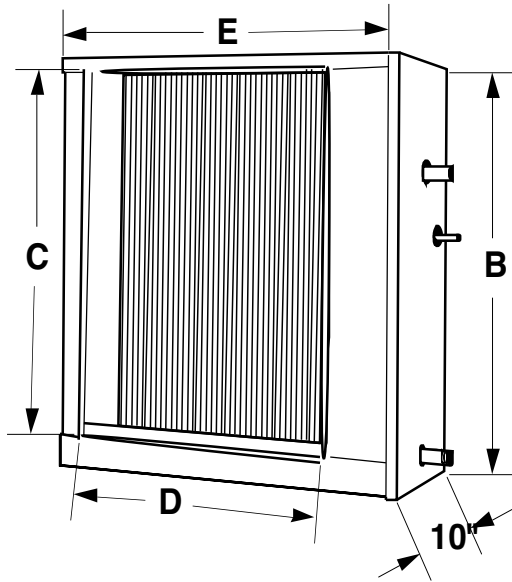

#### GENERAL SPECIFICATIONS

- Standard refrigerant connections: liquid line - 3/8" ODS, suction line - 7/8" ODS.
- Two 3/4" MPT condensate drains.
- Powder-painted metal drain pan. Stainless available.
- Five-year warranty.
- Flowrater standard. Factory or field-installable TXV available.
- Every coil immersion-tested at 500 psi, then nitrogen-pressurized and sealed.
- Heavy gauge embossed galvanized cabinet fully lined with 1/2" faced insulation.
- Rifled copper tubing, enhanced aluminum fins.
- ARI certifiable with all brands of A/C and heat pump systems.
- ETL listed.

ASPEN MODEL	REPLACES	HEIGHT	OPENING		LENGTH	LIST PRICE	
		B	C	D	E	ORIFICE	TXV
BHR24 24	H24F	23-1/2	21	16	21-1/2	\$109	\$140
BHR32 36	H36F	23-1/2	21	16	21-1/2	\$125	\$156
BHR32 48	H49F	23-1/2	21	24	29-1/2	\$158	\$189
BHA32 60	H60F	23-1/2	21	29	35-1/2	\$183	\$214
BHA40 60	H61F	23-1/2	21	29	35-1/2	\$217	\$248