

DIMENSIONS AND SPECIFICATIONS

Aspen Horizontal Coils

Designed to Replace Red T Horizontal Coils

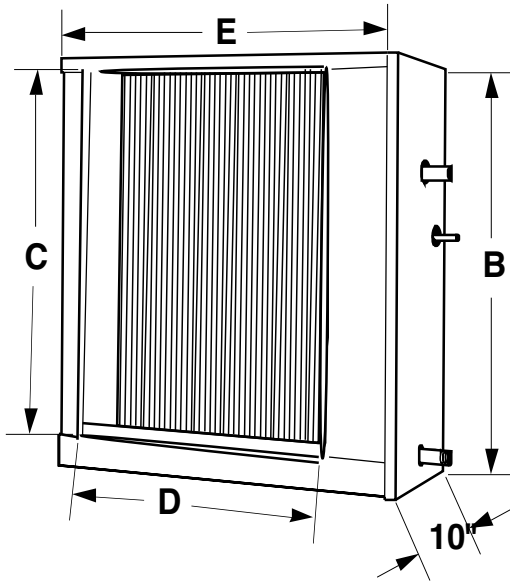

GENERAL SPECIFICATIONS

- Standard refrigerant connections: liquid line - 3/8" ODS, suction line - 7/8" ODS.
- Two 3/4" MPT condensate drains.
- Powder-painted metal drain pan. Stainless available.
- Five-year warranty.
- Flowrater standard. Factory or field-installable TXV available.
- Every coil immersion-tested at 500 psi, then nitrogen-pressurized and sealed.
- Heavy gauge embossed galvanized cabinet fully lined with 1/2" faced insulation.
- Rifled copper tubing, enhanced aluminum fins.
- ARI certifiable with all brands of A/C and heat pump systems.
- ETL listed.

ASPEN MODEL	REPLACES	HEIGHT	OPENING		LENGTH	LIST PRICE	
		B	C	D	E	FLO-RATER	TXV
BHC24 24	RTE524CH	21-1/2	17-1/2	22	27	\$121	\$152
BHC32 36	RTE536CH	21-1/2	17-1/2	22	27	\$141	\$172
BHC32 48	RTE48CH, 548CH	21-1/2	17-1/2	28	33	\$165	\$196
BHC32 60	RTE60CH	25-1/2	21-1/2	28	33	\$186	\$217